

STANLEY[®]
Engineered Fastening



Lockbolt Systems

POP  **Avdel**[®]

Lockbolt Systems

Structural vibration resistant fasteners with high clamp load performance and multi-grip capabilities.



Lockbolt fasteners

Lockbolts are specified whenever robust and reliable fastening is desired. Our intelligent fastening systems and durable, ergonomic installation tools create an ideal assembly solution in any manufacturing environment.

Structural lockbolts consist of a separate pin and collar which are mechanically locked during installation. These fasteners form joints capable of withstanding the toughest applications and environments that traditional rivet and screw joints often cannot provide. They offer exceptional resistance to vibration and material fatigue due to the swaged lock which forms collar material permanently into the circular grooves of the bolt.

Installation

POP Avdel structural lockbolts can be installed quickly and easily without the need for special training or the skilled labour that's often required for other fastening methods. This simple installation process eliminates negative manufacturing influences including examples of RSI (Repetitive Strain Injury) – thus ensuring safety & quality from the first to the last installation.

Applications

Structural lockbolts are mostly used in the automotive, HGV & transportation markets as well as machinery and equipment manufacturing, heating and ventilation, and metal fabrication and construction.

POP Avdel's structural lockbolt range can provide a cost effective solution for any application, often reducing total assembly cost and time as well as inventory.

Mission

STANLEY Engineered Fastening provides structural fastening systems that simplify your production process and improve the quality and functionality of your products. We are not just a provider of fasteners and equipment, together we are a design and development partner for our customers engineering teams.



Contents Page

Systems Range Overview	Structural Lockbolt Systems	4
	Range Overview	5
	Selecting a Lockbolt Fastener	6
	Selection Guide	7 - 8
Lockbolt Range	NeoBolt®	9
	Avdelok®	10
	Avdelok® XT	11
	Maxlok®	12
	Avtainer®	13
	Avbolt®	14
	Customised Designs	15
Installation Equipment	Tool Selection Guide	16
	Genesis® nG3 LB	17
	ProSet® XT4	18
	73200 Model	19
	7287 Model	20
	AV™ Series	21
	Enerpac® Power Units	22 - 23
Data Sheets	NeoBolt®	24 - 27
	Avdelok®	28 - 50
	Avdelok® XT	51 - 58
	Maxlok®	59 - 65
	Avtainer®	66 - 67
	Avbolt®	68 - 69

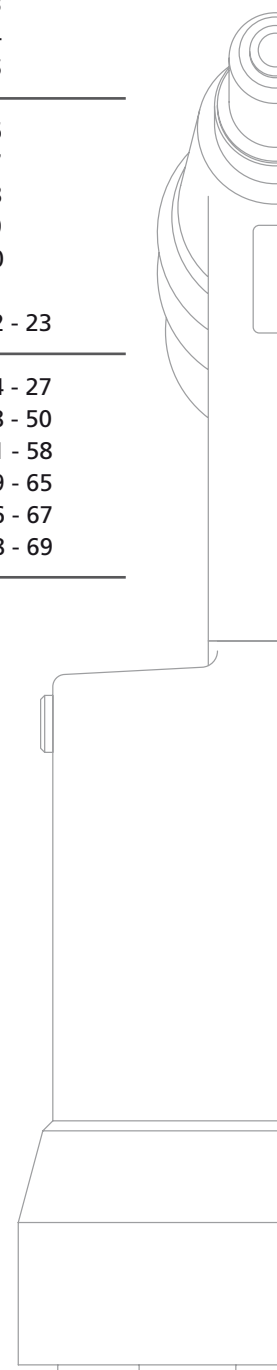
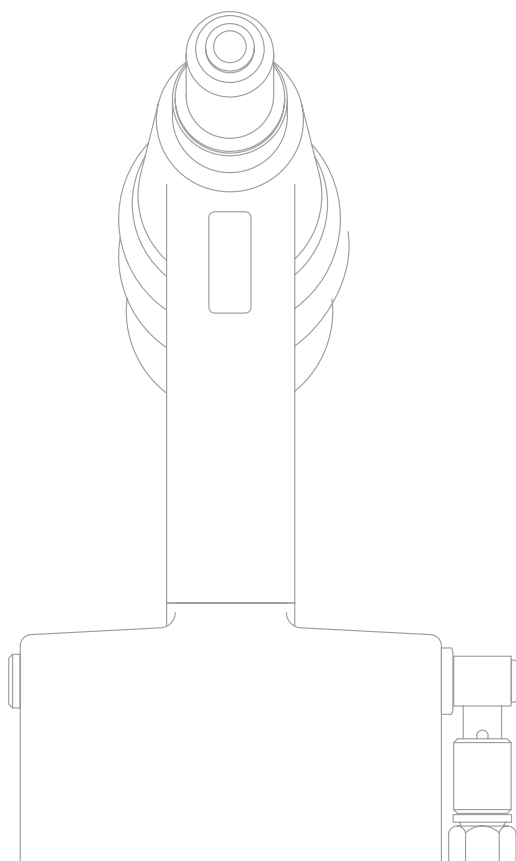
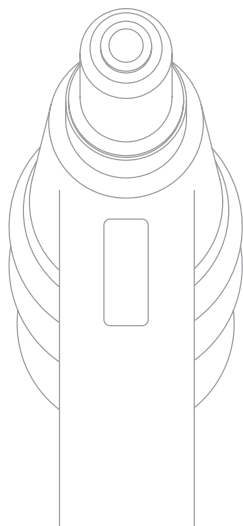

Structural Lockbolt Systems

Lockbolt systems are designed for high strength, secure assembly. Quick and simple to place, durable and long lasting, they are the ideal solution where spot welding is not practical and other methods are costly, time consuming or not possible. Our lockbolt systems have been widely used for many years in demanding engineering industries throughout the world, including vehicle body building, railways, construction, mining and containers.

Benefits of assembly

High speed assembly

Lockbolts are placed in seconds, to provide a secure, long-lasting joint.

High shear and tensile strength

Lockbolts have been designed to deliver the high strength performance required in load-bearing, structural applications.

Consistent, high performance

Designed and manufactured to close tolerances, our lockbolt systems ensure consistently accurate and secure, high strength assembly. Combined with a special purpose tool, our lockbolts eliminate installation errors or variability of clamp associated with conventional assembly methods.

Robust and rugged tools

Designed for use in demanding engineering environments, these tools have a long and reliable track record. They provide consistently accurate and secure installation within a few seconds.

Excellent vibration resistance







As permanent as a weld, lockbolts resist loosening when all other methods fail.

Ease of inspection

A quick and simple visual inspection is sufficient to check that the lockbolt has been correctly installed. Tampering is immediately obvious and enables lockbolt fasteners to be TIR (Transports Internationaux Routiers) approved.



Range overview

Brand	Material	Key features
NeoBolt® 	Steel	No pin break High strength and superior vibration resistance Fast and consistent intallation
Avdelok® 	Aluminium Alloy Steel Stainless Steel	High shear strength High controlled clamp
Avdelok® XT 	Steel	Exceptional shear and tensile strength Sizes from 12.7 mm (1/2") to 28.6 mm (1-1/8")
Maxlok® 	Aluminium Alloy Steel	Wide grip range High shear strength
Avtainer® 	Steel	High shear strength Joins composite panels to metal Leak resistant High speed installation
Avbolt® 	Steel	One side access installation High tensile and shear strength High grip capability

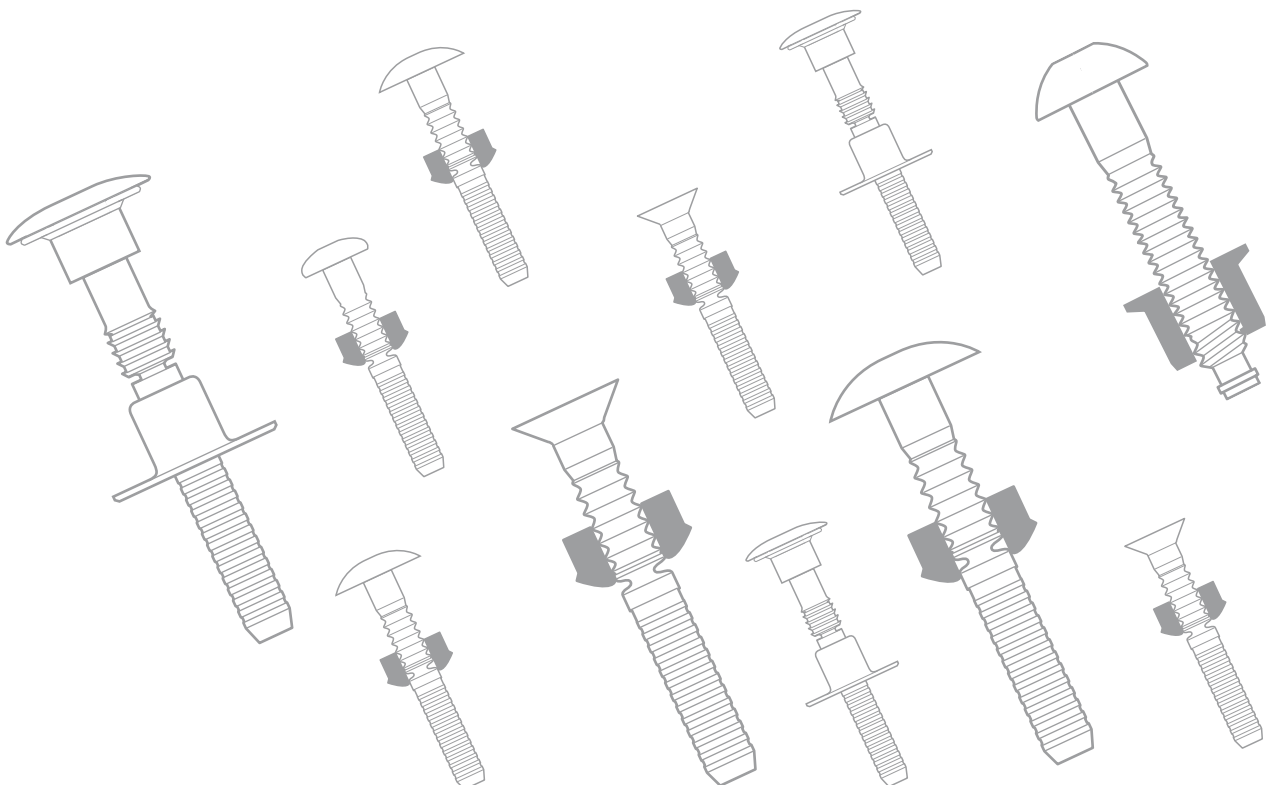

Selecting a Lockbolt Fastener

Selecting a structural lockbolt fastener is a simple process. The factors detailed below are designed to help you identify a fastener suitable for your application:

Fastener selection

Accessibility

If there is only access from one side the Avbolt® structural blind fastener is the only choice. NeoBolt®, Avdelok®, Avdelok® XT, Maxlok® and Avtainer® lockbolts require access from both sides of the component.

Grip range

The fastener should be selected to ensure that the total thicknesses of the parent materials fall within the grip range.

Hole size

This is specified on the relevant technical data sheet for the structural fastener. It is important to control the hole size accurately in order to ensure the performance of the fastener.

Corrosion Resistance

Material and plating selection should be based on the level of corrosion resistance required. Corrosion is best reduced by selecting a fastener material which is the same as the parent material(s). Stainless steel fasteners offer the best corrosion resistance.

Important Information

The information on this page should be used in conjunction with the technical data available on our website where you can also find additional information about corrosion, safety and RoHS.

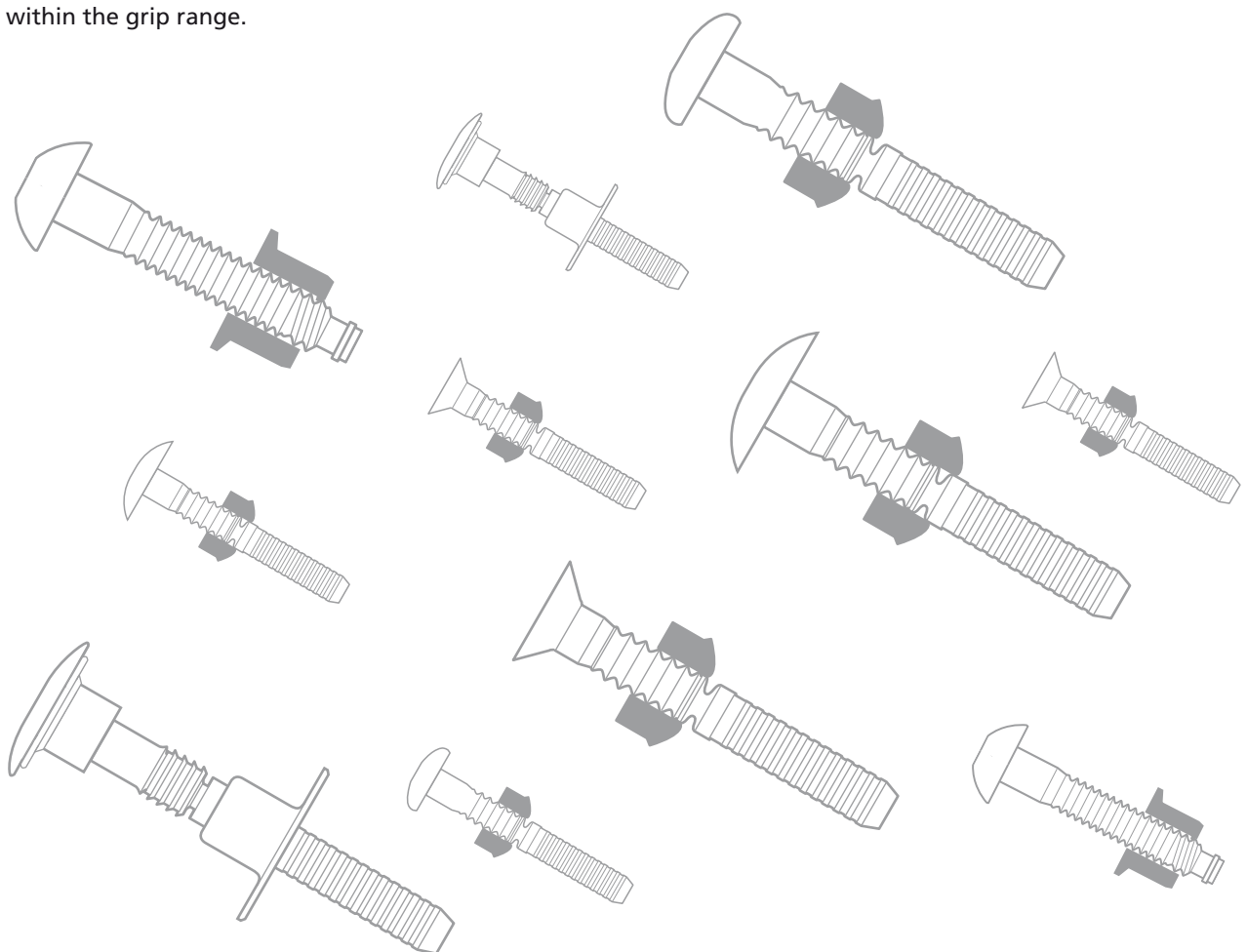

Selection Guide

This selection guide is designed to illustrate which fasteners may be the most suitable for your application. This guide does not include the full range of POP Avdel products; our Applications Engineers are available to advise as to the best solution for your specific application needs.

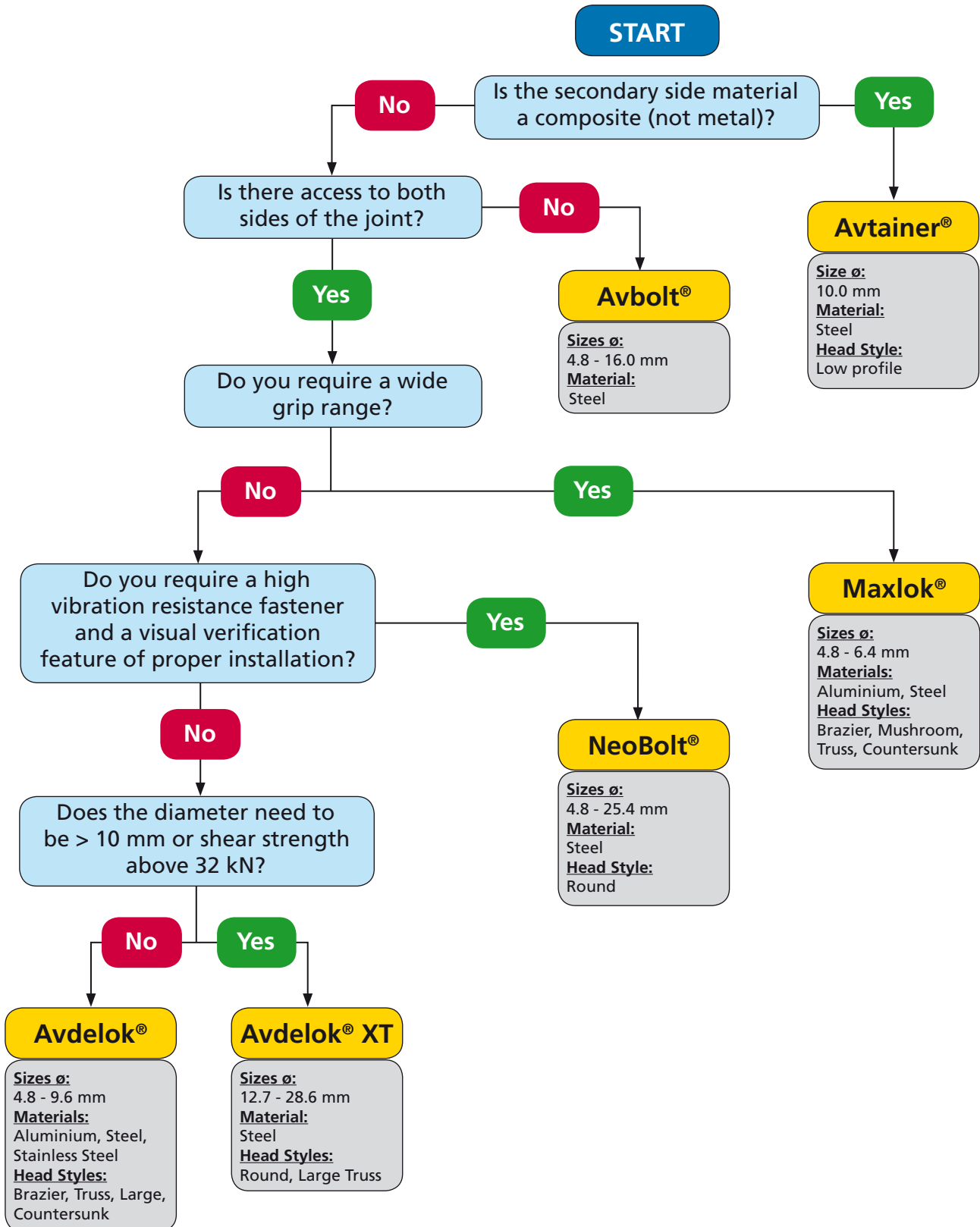

Selection Guide

This table is designed as a guide to help you select the most suitable lockbolt for your particular application. Full technical and performance data for each fastener can also be found on our website or contact your local STANLEY Engineered Fastening representative.

Product Range	Material Pin & Collar			Head Style Pin							Collar			Fastener Size (nom)							Series	Page							
	Aluminium	Steel	Stainless Steel	Brazier head	90° Countersunk	Truss head	Large head	Round head	Mushroom head	Low profile	Full	Half	Flanged	4.8 mm	6.4 mm	8.0 mm	9.6 mm	10.0 mm	12.7 mm	15.9/16 mm		19.1 mm	22.2 mm	25.4 mm	28.6 mm	Description	Data Sheet		
NeoBolt®	•							•				•													12851	9	24		
Avdelok®	•			•							•	•	•	•												2621	10	28	
	•				•						•	•	•	•												2622	10	31	
	•					•					•	•	•	•												2624	10	34	
		•									•		•	•	•	•											2691	10	37
	•										•	•	•	•	•												2801	10	40
	•				•						•	•	•	•	•												2802	10	43
	•					•					•	•	•	•	•												2803	10	46
	•							•			•	•	•		•												2804	10	49
Avdelok® XT	•							•			•								•	•	•	•	•	•		2851	11	51	
	•						•				•	•							•	•	•	•	•			2854	11	55	
Maxlok®	•			•							•		•	•												1901	12	59	
	•				•						•		•													1902	12	60	
	•							•			•		•	•												1903	12	61	
	•					•					•		•	•												1905	12	62	
	•				•						•		•	•												1921	12	63	
	•							•			•		•													1923	12	64	
	•					•					•		•	•												1925	12	65	
Avtainer®	•								•								•									2311	13	66	
Avbolt®	•																	•	•	•						21001	14	68	
	•												•	•	•											21021	14	69	

NeoBolt®

High strength, unmatched vibration resistant lockbolts without pin break for heavy duty structural applications, providing a collar 'fit-up' feature for easy pre-assembly.



Key features and benefits

No Pin Break:

- No metal waste, eco-friendly
- No dropped stems improving working area safety
- Avoid corrosion at stem break point (vs. traditional lockbolts)
- Reduced pin size and weight for lower warehousing and shipping cost

Maintenance Free:

- No torque or re-torque is required

Fast & Shockless Installation:

- Reduces operator fatigue and installation noise
- Fine pitch pin groove design for superior vibration resistance vs. traditional lockbolts and nut & bolt settings
- Collar 'fit-up' feature for easy pre-assembly of the joint, ideal for upside-down installation
- Radial bar indicators on collar for quick visual swage inspection upon placing

Specifications

Sizes:

4.8 mm – 25.4 mm
(3/16" – 1")

Material:

Steel

Head Style:

Round

Collar option:

Flanged

Patent protected.

Typical placing sequence

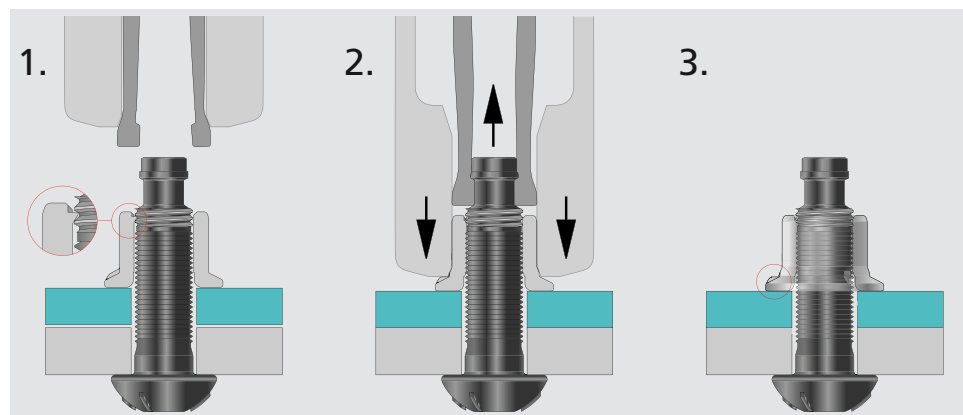

Please visit our website for fastener placing animations.

Assembly applications

- Railway
- Truck & Trailer
- Commercial Vehicles
- Solar & Wind Energy
- Bridge Building
- Mining Equipment
- Screening Equipment
- Fencing & Security Screens
- Construction
- Overland Infrastructure
- Power & Utility Services



Avdelok[®]

High strength, vibration resistant lockbolts with high controlled clamp.



Key features and benefits

- High shear strength for high strength assembly
- High controlled clamp provides excellent vibration resistance
- Quick to install across a wide range of applications
- Wide choice of materials, sizes, head styles and collar options to suit a wide variety of applications
- Easy to inspect for tampering
- High security tamper resistance - TIR approved
- Steel Avdelok pins typically offer comparable values to property class 5.8 threaded products
- Robust and rugged installation tools

Specifications

Sizes:

4.8 mm to 9.6 mm
(3/16" to 3/8")

Materials:

Aluminium alloy, Steel,
Stainless steel

Head Styles:

Brazier, Countersunk,
Truss, Large

Collar options:

Full, Half, Flanged

Typical placing sequence

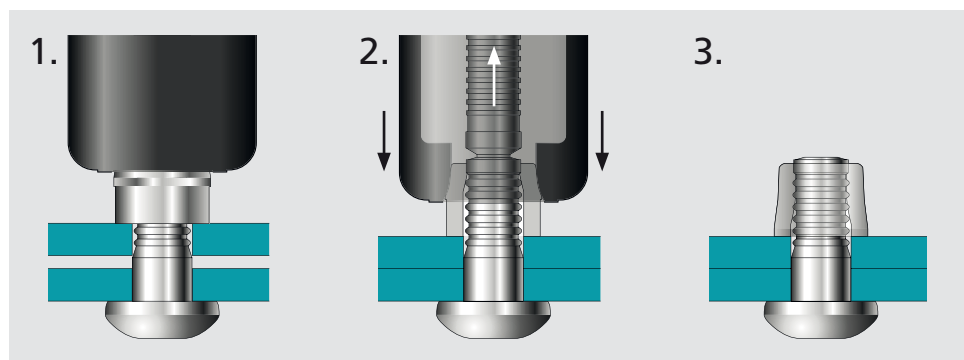

Please visit our website for fastener placing animations.

Assembly applications

- Commercial vehicles
- Truck & trailer
- Heating systems
- Steel construction
- Solar panels
- Railway
- Mining

Heating systems



Ventilator frame



Commercial vehicles

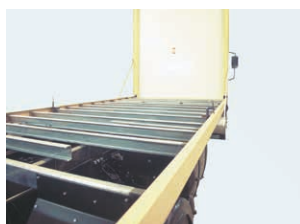

Car seat



Avdelok[®] XT

Large diameter lockbolt for demanding engineering applications.



Key features and benefits

- Exceptional shear and tensile strength provides consistent high performance, required in load-bearing structural applications
- Excellent vibration resistance
- High security tamper resistance - TIR approved
- Tolerates variation in joint - allows angled installation up to 7°
- Quick and easy to install - requires minimum skill labour
- Simple installation tooling eliminates the cost of calibration and reduces maintenance
- Consistent installation prevents rework and associated costs
- Simple visual inspection for quality assurance joints
- Installed Avdelok XT fasteners provide a minimum shear, tensile and pre-load strength which is equivalent to or exceeds ISO898-1 property class 8.8 or ASTM A-325 standards

Specifications

Sizes:

12.7 mm to 28.6 mm
(1/2" to 1-1/8")

Materials:

Steel

Head Styles:

Round, Large Truss Head

Collar options:

Full, Flanged

Typical placing sequence

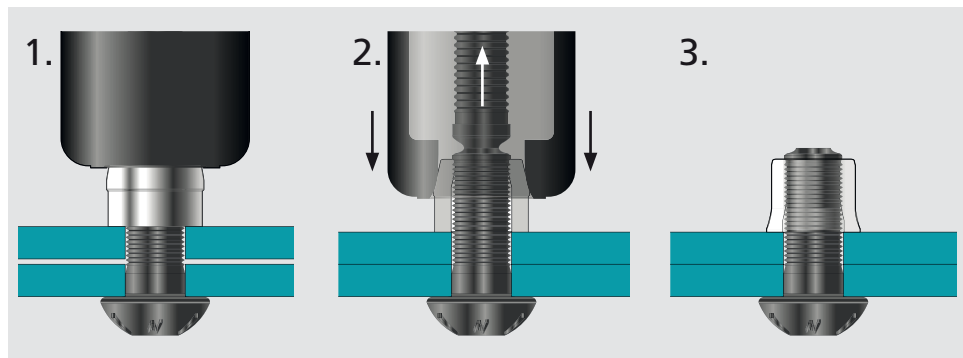

Please visit our website for fastener placing animations.

Assembly applications

- Commercial vehicles
- Steel construction
- Bridge building/repair
- Renewable energies
- Railway/rail track
- Mining

Commercial vehicles



Bridge building



Rail track



Lattice towers



Solar power plants



Solar power plants (detail)



Maxlok[®]

High strength, vibration resistant lockbolts with multi-grip capability.



Key features and benefits

- Wide grip range reduces inventory, simplifies stock control, and accommodates wide variations in material thickness
- High shear strength for high strength assembly
- High, controlled clamp provides excellent vibration resistance
- Wide range of special purpose installation tools
- Quick to install across a wide range of applications
- Brazier, countersunk, mushroom and truss head styles suit a wide variety of applications
- Easy to inspect tampering
- High security tamper resistance - TIR approved

Specifications

Sizes:

4.8 mm to 6.4 mm
(3/16" to 1/4")

Materials:

Aluminium alloy, Steel

Head Styles:

Brazier, Mushroom,
Truss, Countersunk

Collar option:

Flanged

Typical placing sequence

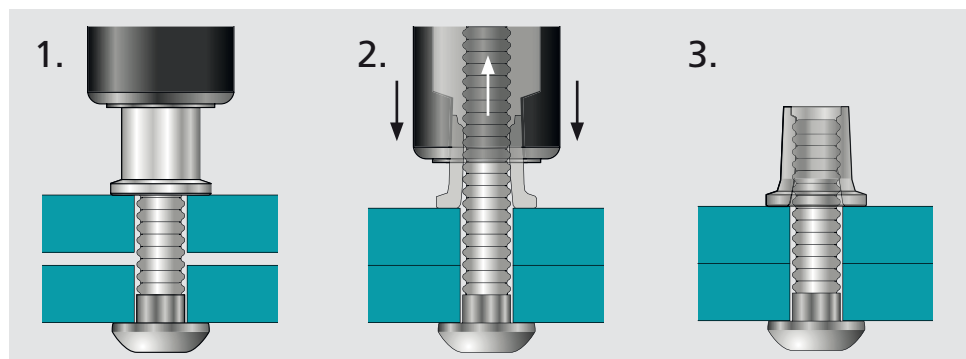

Please visit our website for fastener placing animations.

Assembly applications

- Commercial vehicles
- Heating and ventilation
- Frame building

Commercial vehicles

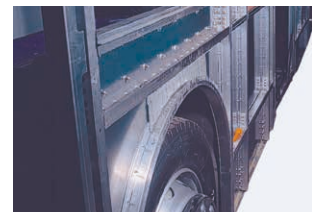

Fan bearing arm

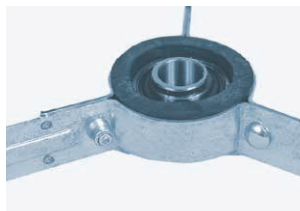

Avtainer[®]

High strength, steel fastener and shell designed for joining composite panels to metal.



Key features and benefits

- Prevents cracking and pull through of composite materials
- Ideal for the assembly of GRP vehicle panels
- High shear strength for high strength assembly
- Underhead Santoprene[®] seal for a water/air tight joint
- Internally locked stem provides a secure, vibration resistant joint
- Low profile head and shell give a neat appearance
- Smaller shell size available for use against metal surfaces
- Optional encapsulated heads to match the surrounding colour
- Quick to install with Genesis[®] power tools
- Easy to inspect for tampering
- High security tamper resistance - TIR approved

Specifications Typical placing sequence

Sizes:
10.0 mm (3/8")
Material:
Steel
Head Style:
Low profile
Option:
Encapsulated heads

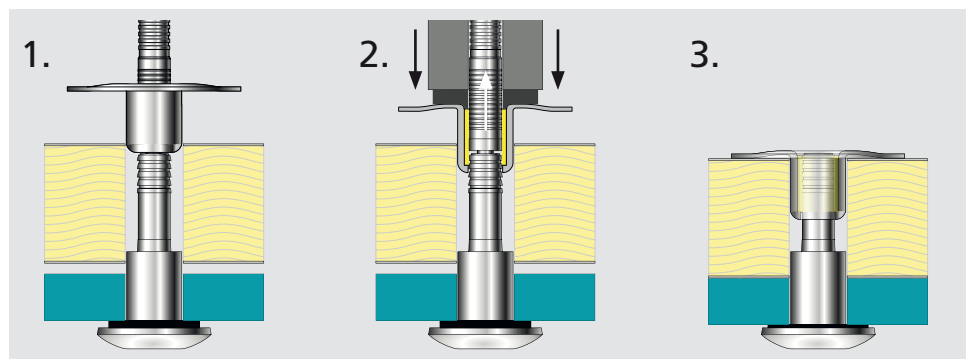

Please visit our website for fastener placing animations.

Assembly applications

- Commercial vehicles
- Container



Avbolt® Structural Blind Fastener

The Avbolt structural fastener is a high strength, tamper resistant, blind steel fastener designed for use in heavy-duty structural applications. It offers a high tensile and shear strength normally only possible with non blind lockbolts and combines it with the installation speed of blind products.



Avbolt 10.0, 12.7 and 16.0 mm:
3 piece design (sleeve, collar, stem)



Avbolt 4.8, 6.4 and 8.0 mm:
2 piece design (sleeve with collar, stem)

Key features and benefits

- Use on blind sided application
- High tensile and shear strength for heavy-duty applications
- Wide grip capability suits a variety of material thicknesses
- Ideal for areas with restricted access
- Locking feature creates a vibration resistant joint and prevents loose stems
- Fast installation
- High security tamper resistance - TIR approved
- Simple tooling requires only minimum operator skill

Specifications Typical placing sequence (3 piece design)

Sizes:

4.8 mm to 16.0 mm
(3/16" to 5/8")

Material:

Steel

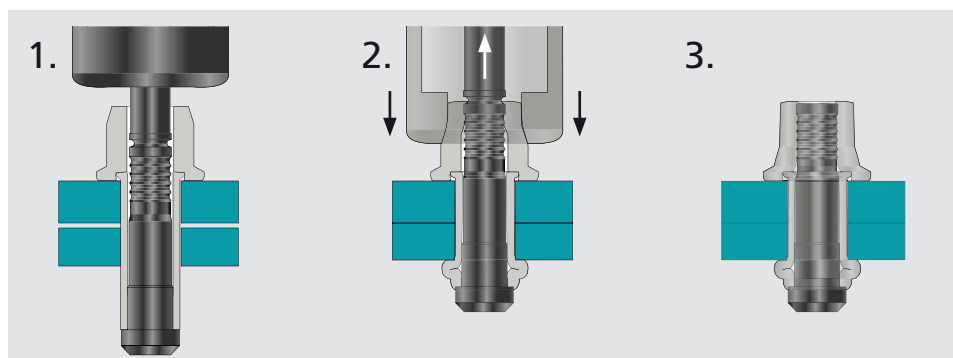

Patent Protected.

Please visit our website for fastener placing animations.

Assembly applications

- Automotive
- Truck and trailer
- Construction
- Container
- Renewable energies
- Railway
- Mining
- Security fencing

Security fence

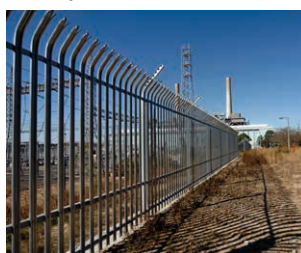

Steel construction



Hinge attachment



Customised Designs

As you would expect from a leader in fastening solutions, we can design and manufacture lockbolt fastener with a wide variety of forms and finishes to meet your unique assembly requirements. Shown below are just a few examples of our customized lockbolt capabilities. Whether you require custom fastener geometry, a particular finish, different fastener material, limited access placing tooling, or anything else we don't offer as standard, please contact us to discuss your special requirements.



Avdelok® Lockbolt (pin) - Stepped Head (Standard Strength)

- Steel, Phosphate + Delta Seal® GZ Black
- Shouldered head provides a pivot in a car seat mechanism



Avdelok® Lockbolt (pin) - High Strength + Magni Finish + Identification Colour

- Steel, Magni 565 - Green
- Specific colour coding for identification purposes



Avdelok® Lockbolt (pin) - Al Alloy 7075 to T73 heat treatment

- 7075 Al Alloy, mechanical polish
- Pin in 7075 aluminium with special heat treatment for improved corrosion resistance in an oil storage tank



Avdelok® Lockbolt (pin) - Extended Grip Range + Special Head Style

- Steel, 8 µm Min Zinc + Clear Cr3 Passivation
- Additional lock grooves increase the grip range of Avdelok pins



Maxlok® Lockbolt (pin & collar) - Large Flange Head

- 8 µm Min Zinc + Clear Cr3 Passivation
- Larger pin head and collar flange size to spread load in soft application materials



Avdelok® Lockbolt (pins & collar) - Extra Long Pin, 316 Stainless Steel

- Grade 316 Stainless Steel
- Non-magnetic 316 stainless steel pins for use in electric motors



Maxlok® Lockbolt (collar) - Shorter Collar without Recess

- Steel, 8 µm Min Zinc + Clear Cr3 Passivation
- Shorter collar for applications demanding limited protrusion from the joint



Avbolt® Structural Blind Fastener - Underhead Rimlex® Seal

- Improves sealing capability without manually fitted seals

Installation Tools

Tool Selection Guide

This table is designed as a guide to help you select the most suitable tool for your particular lockbolt.

Please note that all tools require fastener specific nose assemblies.

Full technical data can also be found on our website or contact your STANLEY Engineered Fastening representative.

Fastener Type	Size	Installation Tool							
		Genesis® nG3 LB	ProSet® XT4	73200	7287	AV™ 10*	AV™ 15*	AV™ 30*	AV™ 50*
NeoBolt®	4.8 mm (3/16")	•							
	6.4 mm (1/4")	•							
	8.0 mm (5/16")			•					
	9.6 mm (3/8")				•				
	12.7 mm (1/2")						•		
	16.0 mm (5/8")							•	
	19.1 mm (3/4")							•	
	25.4 mm (1")								•
Avdelok®	4.8 mm (3/16")		•	•	•				
	6.4 mm (1/4")		•	•	•				
	8.0 mm (5/16")			•	•				
	9.6 mm (3/8")			•	•	•			
Avdelok® XT	12.7 mm (1/2")						•	•	
	16.0 mm (5/8")							•	
	19.1 mm (3/4")							•	
	22.2 mm (7/8")								•
	25.4 mm (1")								•
	28.6 mm (1-1/8")								•
Maxlok®	4.8 mm (3/16")		•	•	•				
	6.4 mm (1/4")		•	•	•				
Avtainer®	10.0 mm (3/8")		•	•	•				
Avbolt®	4.8 mm (3/16")			•	•				
	6.4 mm (1/4")			•	•				
	8.0 mm (5/16")			•	•	•			
	10.0 mm (3/8")					•			
	12.7 mm (1/2")						•	•	
	16.0 mm (5/8")							•	

*All AV™ Series tools require Enerpac® Power Unit for operation.

Installation Tools

Genesis® nG3 LB

Lightweight pneumatic/hydraulic power tool for the reliable placement of NeoBolt® lockbolts \varnothing 4.8 mm (3/16") and 6.4 mm (1/4").

Features and Benefits

- Ergonomic design reduces operator fatigue
- Quick cycle time increases productivity
- Integral cycle counter helps establish accurate service intervals
- Toughened plastic body and heavy duty rubber base make it a robust tool for a long working life
- Soft touch rubber grip on handle
- Adjustable vacuum air flow minimizes air consumption
- Can be suspended

Specifications

Air pressure	5 - 7 bar
Free air volume required @5.5 bar	4.3 litres
Stroke (min.)	26 mm
Pull force @5.5 bar	12.9 kN
Cycle time (approx.)	1.2 sec
Noise level	<75 dB(A)
Weight incl. nose equipment	2.4 kg

Base Tool

Part Number	Description
71256-02000	Genesis nG3 LB base tool without nose equipment



Coming soon

Installation Tools

ProSet® XT4

Versatile lightweight pneumatic/hydraulic power tool capable of placing Avdelok® and Maxlok® lockbolts up to \varnothing 6.4 mm (1/4"), and \varnothing 10.0 mm (3/8") Avtainer®. High force to weight ratio and innovative ergonomic design delivers maximum user efficiency and comfort. The tool features an ultra-high tensile piston rod for maximum tool life and a hydraulic damping for smooth operation.

Features and Benefits

- High force-to-weight ratio
- Quick disconnect nose housing and jaw case for easy maintenance and service
- Clear quick release mandrel collector bottle reduces downtime
- Integral exhaust valves for fast setting cycles
- Class-leading lightweight construction with balanced handling
- Comfortable, low activation force trigger
- Adjustable vacuum exhaust direction
- Air isolation switch during mandrel collector bottle removal
- On/Off, left or right swivel air fitting provides flexibility and conserves energy

Specifications

Air pressure	5 - 7 bar
Free air volume required @5.5 bar	6.3 litres
Stroke (min.)	18 mm
Pull force @5.5 bar	23.0 kN
Cycle time (approx.)	1.0 sec
Noise level	77.9 dB(A)
Weight without nose equipment	2.0 kg

Base Tool

Part Number	Description
76004-00001	ProSet XT4 tool without nose equipment



Installation Tools

73200 Model

The hydro-pneumatic 73200 tool is designed to place NeoBolt® lockbolts \varnothing 8.0 mm (5/16"), Avdelok®, Maxlok® and Avtainer® lockbolts up to \varnothing 10.0 mm (3/8") as well as Avbolt® fasteners up to \varnothing 8.0 mm (5/16"). Featuring an innovative patent protected hydraulic design and using the latest sealing and guiding technology, this new tool delivers unmatched fastening efficiency and dependability.

Features and Benefits

- Forged aerospace-grade aluminium alloy head and handle delivers the optimum combination of low weight, strength and durability
- Designed for heavy duty use over long periods of time, even in the most demanding environments
- Balanced ergonomic design and lightweight Genesis® pneumatic trigger operation
- Quick and simple operation minimizes operator fatigue and reduces assembly time to a minimum
- Wide choice of nose assemblies to suit access restrictions of the application
- Collar cropper attachment available to remove collars from installed Avdelok lockbolts

Specifications

Air pressure		5 - 7 bar
Free air volume required	@5.5 bar	15.6 litres
Stroke (min.)		20 mm
Pull force	@5.5 bar	28.5 kN
Cycle time (approx.)		3 seconds
Noise level		75 dB(A)
Weight without nose equipment		4.9 kg

Base Tool

Part Number	Description
73200-02000	73200 Model base tool without nose equipment



Installation Tools

7287 Model

Hydro-pneumatic split tool with a lightweight placing head able to place NeoBolt® lockbolts \varnothing 9.6 mm (3/8"), Avdelok® and Avtainer® lockbolts up to \varnothing 10.0 mm (3/8"), Avbolt® fasteners up to \varnothing 8.0 mm (5/16"), and all other lockbolts up to \varnothing 8.0 mm (5/16").

Features and Benefits

- Extended stroke and pull force
- Installation of large fasteners with single pull action for high placement speed
- Short cycle time can increase assembly capacity
- Lightweight placing head reduces operator fatigue
- Remote intensifier mounted on castors for flexible use in the assembly line
- Wide choice of directly interchangeable 73200 model nose assemblies to suit the access restrictions of the application
- Can be fitted with a collar cropper to remove installed Avdelok lockbolts

Specifications

Air pressure	5 - 7 bar
Free air volume required @5.5 bar	3.5 litres
Stroke (min.)	29 mm
Pull force @5.5 bar	32.4 kN
Cycle time (approx.)	1.7 seconds
Noise level	75 dB(A)
Weight without nose equipment	
- Pistol	1.47 kg
- Total (pistol + intensifier)	40 kg

Base Tool

Part Number	Description
07287-00200	7287 Model base tool without nose equipment



Installation Tools

AV™ Series Tools

The AV hydro-electric power tool line is capable of setting all Avdelok® and Avdelok® XT lockbolts from as small as 9.6 mm (3/8") to as large as 28.6 mm (1-1/8"). It also has the flexibility needed to set NeoBolt® lockbolts 12.7 mm (1/2") up to 25.4 mm (1") and Avbolt® sizes 8.0 mm (5/16") through 16.0 mm (5/8").

Features and Benefits

- Robust and highly durable installation tools designed for a long working life in extreme conditions
- Choice of placing heads and nose equipment to suit the entire range of large diameter Avdelok XT lockbolts as well as NeoBolt lockbolts 12.7 - 25.4 mm and Avbolt fasteners 8.0 - 16.0 mm
- Ergonomic and compact design for optimised operator comfort
- Easy-to-change nose equipment and range of hydraulic hoses in different lengths enable the tool to be adapted to suit local assembly requirements
- Low maintenance

Specifications

Specifications		AV10 73430-02000	AV15 73432-02000	AV30 73434-02000	AV50 73435-02000
Operating pressure	Pull Return	510 bar 200 bar			
Force	Pull at stated pull pressure Push Off at stated return pressure	55 kN 26 kN	80 kN 37.5 kN	175 kN 81 kN	340 kN 161 kN
Piston stroke		25 mm	32 mm	41 mm	55 mm
Weight without nose equipment		3.5 kg	4.5 kg	6.8 kg	13.5 kg
Power / Weight ratio		15.7:1	17.7:1	25.7:1	17.9:1
Swept volume	Pull Return	28.5 cm ³ 34.7 cm ³	60.3 cm ³ 71.1 cm ³	115.0 cm ³ 140.3 cm ³	386.7 cm ³ 467.2 cm ³



AV™ 10



AV™ 15



AV™ 30



AV™ 50

Installation Tools

Enerpac® PRO Series Pumps

STANLEY Engineered Fastening has partnered with Enerpac, the World Leader in Hydraulic Equipment to offer a specialised selection of reliable, durable and versatile high-pressure hydraulic pumps to power all AV™ Hydro-Electric Power Tools.

Features and Benefits

- High-efficiency hydraulic pump design; higher oil flow and bypass pressure, cooler running and requires 18% less current draw than comparable pumps
- Powerful electric motor provides high power-to-weight ratio and excellent low-voltage operating characteristics
- High-strength, molded composite shroud protects electric pump motor and electronics, while providing an ergonomic, non-conductive handles for easy portability
- Full sight oil level glass & durable steel reservoir
- All pump configurations able to power all AV series tools



Pump versions with heat exchanger are suitable for high volume productions.

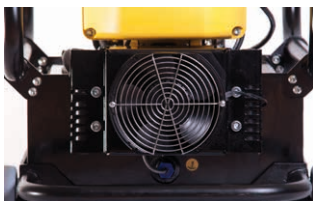

Reservoir heat exchanger



Full sight oil level glass



LCD screen

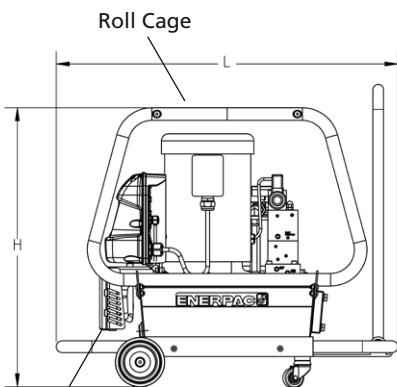

Heat Exchanger

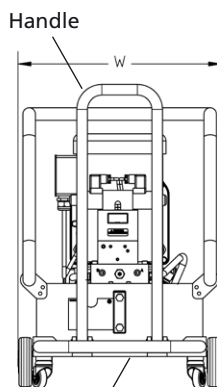

Wheel Base

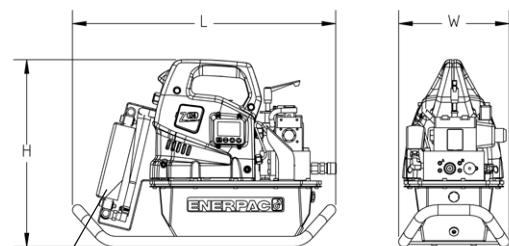

Heat Exchanger

Skid Bar

PRO & PRO PLUS Type Units

F Type includes Heat Exchanger, Roll Cage, Wheel Base & Handle

A Type does not include Heat Exchanger, Roll Cage, Wheel Base & Handle

PRO-E Type Unit

Includes Heat Exchanger and Skid Bar

There are different hose lengths available. Please select the length according to your application:

Hose Assembly Length	Part Number
5 metre	07008-00448
10 metre	07008-00449
15 metre	07008-00450



Installation Tools

Technical Data

Hydraulic pumps for high volume production levels (all models with LCD Display, Heat Exchanger, Roll Cage, Wheel Base & Handle)								
Model		PRO 220-F	PRO 240-F	PRO 240 PLUS-F	PRO 415-F	PRO 415 PLUS-F	PRO 480-F	PRO 480 PLUS-F
Part Number		76502- 02500	76503- 02500	76508- 02500	76504- 02500	76510- 02500	76505- 02500	76511- 02500
Motor Type		Induction	Induction	Induction	Induction	Induction	Induction	Induction
Power	kW	1.1	1.1	5.6	1.1	5.6	1.1	5.6
Voltage	V	208 - 240	208 - 240	208 - 240	380 - 415	380 - 415	460 - 480	460 - 480
Frequency	Hz	50/60	50/60	50/60	50/60	50/60	50/60	50/60
Phase		1	3	3	3	3	3	3
Full Load	A	6.8	6.8	16.8	3.0	10.2	2.4	8.4
Reservoir	litres	10	10	10	10	10	10	10
Output flow rate (l/min)	50 bar	8.2	8.2	12.2	8.2	12.2	8.2	12.2
	700 bar	0.82	0.82	2.7	0.82	2.7	0.82	2.7
Sound	dB(A)	75	75	75	75	75	75	75
Weight incl. oil	kg	86	86	113	86	113	86	113
Dimensions (mm)	L	865	865	865	865	865	865	865
	W	410	410	410	410	410	410	410
	H	682	682	682	682	682	682	682

Hydraulic pumps for medium volume and small batch production levels (all models with LCD Display)

Model		PRO 220E-D	PRO 220-A	PRO 240-A	PRO 240 PLUS-A	PRO 415-A	PRO 415 PLUS-A	PRO 480-A	PRO 480 PLUS-A
Part Number		76507- 02300	76502- 02000	76503- 02000	76508- 02000	76504- 02000	76510- 02000	76505- 02000	76511- 02000
Motor Type		Universal	Induction	Induction	Induction	Induction	Induction	Induction	Induction
Power	kW	1.25	1.1	1.1	5.6	1.1	5.6	1.1	5.6
Voltage	V	208 - 240	208 - 240	208 - 240	208 - 240	380 - 415	380 - 415	460 - 480	460 - 480
Frequency	Hz	50/60	50/60	50/60	50/60	50/60	50/60	50/60	50/60
Phase		1	1	3	3	3	3	3	3
Full Load	A	11.0	6.8	6.8	16.8	3.0	10.2	2.4	8.4
Reservoir	litres	4	10	10	10	10	10	10	10
Output flow rate (l/min)	50 bar	8.8	8.2	8.2	12.2	8.2	12.2	8.2	12.2
	700 bar	1.0	0.82	0.82	2.7	0.82	2.7	0.82	2.7
Sound	dB(A)	85 - 90	75	75	75	75	75	75	75
Weight incl. oil	kg	36	51	51	78	51	78	51	78
Dimensions (mm)	L	635	559	559	559	559	559	559	559
	W	267	384	384	384	384	384	384	384
	H	450	457	457	457	457	457	457	457
Heat Exchanger		Yes	No	No	No	No	No	No	No
Skid Bar		Yes	No	No	No	No	No	No	No



English	Français	Deutsch	Italiano	Español
Round head	Tête ronde	Rundkopf	Testa tonda	Cabeza alomada
Pin: Medium carbon steel ≤ ø9,6 = Silver Magni 565 ¹⁾ ≥ ø12,7 = Black oxide (oiled) ¹⁾	Tige: Acier ≤ ø9,6 = Silver Magni 565 ¹⁾ ≥ ø12,7 = Oxyde noire (huilé) ¹⁾	Bolzen: Stahl ≤ ø9,6 = Silver Magni 565 ¹⁾ ≥ ø12,7 = Schwarz/brüniert (geölt) ¹⁾	Bullone: Acciaio ≤ ø9,6 = Silver Magni 565 ¹⁾ ≥ ø12,7 = Anodizzato nero (lubrificato) ¹⁾	Vástago: Acero ≤ ø9,6 = Silver Magni 565 ¹⁾ ≥ ø12,7 = Pavonado (lubricado) ¹⁾
Collar: Low carbon steel Zinc plated ¹⁾	Bague: Acier Zingué ¹⁾	Schließring: Stahl Verzinkt ¹⁾	Collare: Acciaio Zincato ¹⁾	Collar: Acero Zincado ¹⁾

1) other surface finishes available upon request / d'autres finitions de surfaces disponibles sur demande / andere Oberflächen auf Anfrage / altre finiture superficiali sono disponibili su richiesta / disponibles otros acabados superficiales bajo pedido

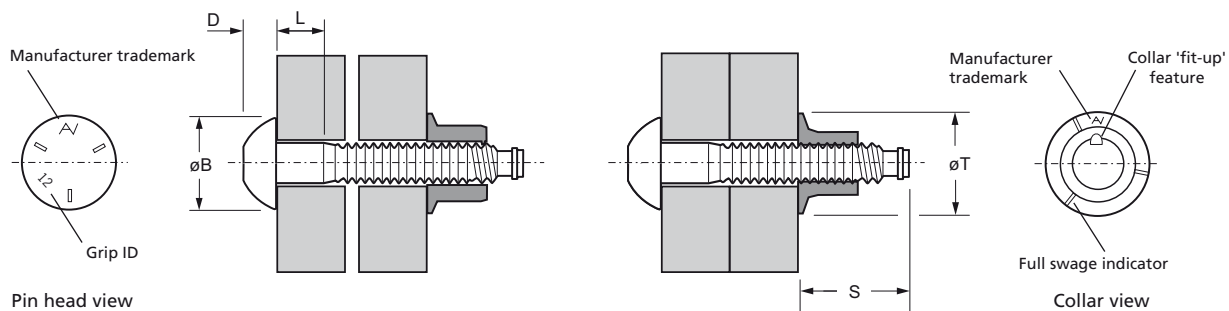

ø nom.	e			Grip range		L nom.	øB nom.	D nom.	S at grip e max.	øT nom.	Part No/ref	
	ID	e min. ²⁾	e max. ²⁾	min.	max.						Pin	Collar
4.8 (3/16")	4	1.33	9.83	5.00	5.56	2.46	8.64	3.01	e min. = 20.04 e max. = 11.54	9.60	12851-60604	12801-30600
	6	4.50	13.00			5.64					12851-60606	
	8	7.68	16.18			8.81					12851-60608	
	10	10.85	19.35			11.99					12851-60610	
	12	14.03	22.53			15.16					12851-60612	
	14	17.20	25.70			18.34					12851-60614	
	16	20.38	28.88			21.51					12851-60616	
	18	23.55	32.05			24.69					12851-60618	
	20	26.73	35.23			27.86					12851-60620	
6.4 (1/4")	4	3.33	9.83	6.60	7.13	1.98	11.47	4.01	e min. = 22.21 e max. = 15.71	12.80	12851-60804	12801-30800
	6	6.50	13.00			5.16					12851-60806	
	8	9.68	16.18			8.33					12851-60808	
	10	12.85	19.35			11.51					12851-60810	
	12	16.03	22.53			14.68					12851-60812	
	14	19.20	25.70			17.86					12851-60814	
	16	22.38	28.88			21.03					12851-60816	
	18	25.55	32.05			24.21					12851-60818	
	20	28.73	35.23			27.38					12851-60820	
8.0 (5/16")	4	3.73	10.53	8.20	9.12	1.68	14.34	5.02	e min. = 25.77 e max. = 18.97	15.99	12851-61004	12801-31000
	6	6.90	13.70			4.85					12851-61006	
	8	10.08	16.88			8.03					12851-61008	
	10	13.25	20.05			11.20					12851-61010	
	12	16.43	23.23			14.38					12851-61012	
	14	19.60	26.40			17.55					12851-61014	
	16	22.78	29.58			20.73					12851-61016	
	18	25.95	32.75			23.90					12851-61018	
	20	29.13	35.93			27.08					12851-61020	

all dimensions in mm / en millimètre / alle Maße in mm / in millimetri / en milímetros

2) Grip range with recommended POP Avdel installation tools / Plage de serrage avec les outils d'installation POP Avdel recommandées / Klemmbereich mit empfohlenen POP Avdel Verarbeitungsgeräten / Gamma grip con i raccomandati strumenti di installazione POP Avdel / Rango de espesores con las herramientas de colocación recomendadas POP Avdel

NeoBolt® 12851 Series
Lockbolt Fastener

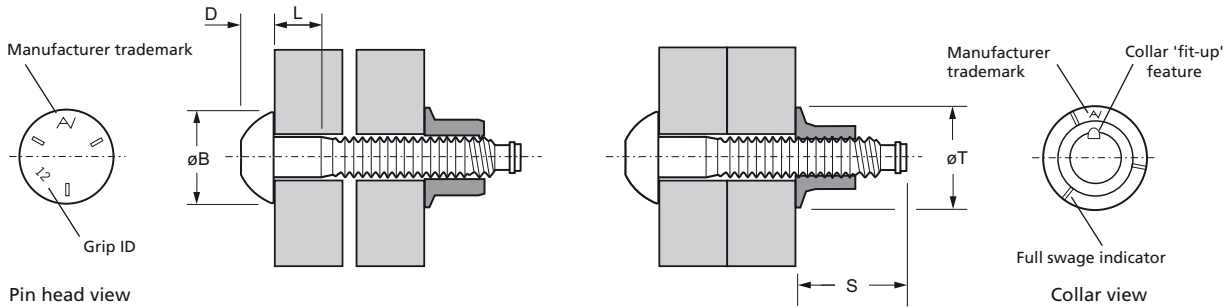

ø nom.	e			L		øB nom.	D nom.	S at grip e max.	øT nom.	Part No/ref	
	ID	e min. ²⁾	e max. ²⁾	min.	max.					Pin	Collar
9.6 (3/8")	4	1.45	11.15	9.80	10.71	1.55	17.21	6.02	19.19	12851-61204	12801-31200
	6	4.63	14.33			4.72					
	8	7.80	17.50			7.90					
	10	10.98	20.68			11.07					
	12	14.15	23.85			14.25					
	14	17.33	27.03			17.42					
	16	20.50	30.20			20.60					
	18	23.68	33.38			23.77					
	20	26.85	36.55			26.95					
	24	33.20	42.90			33.30					
12.7 (1/2")	4	7.50	15.75	13.10	14.28	4.60	22.94	8.00	26.15	12851-11604	12801-31600
	8	13.85	22.10			10.95					
	12	20.20	28.45			17.30					
	16	26.55	34.80			23.65					
	20	32.90	41.15			30.00					
	24	39.25	47.50			36.35					
	28	45.60	53.85			42.70					
	32	51.95	60.20			49.05					
	36	58.30	66.55			55.40					
	40	64.65	72.90			61.75					
	44	71.00	79.25			68.10					
	48	77.35	85.60			74.45					
	52	83.70	91.95			80.80					
	56	90.05	98.30			87.15					
	60	96.40	104.65			93.50					
	64	102.75	111.00			99.85					
68	109.10	117.35	106.20								
72	115.45	123.70	112.55								
76	121.80	130.05	118.90								
16.0 (5/8")	4	4.90	15.75	16.30	17.46	4.60	29.00	10.00	31.74	12851-12004	12801-32000
	8	11.25	22.10			10.95					
	12	17.60	28.45			17.30					
	16	23.95	34.80			23.65					
	20	30.30	41.15			30.00					
	24	36.65	47.50			36.35					
	28	43.00	53.85			42.70					
	32	49.35	60.20			49.05					
	36	55.70	66.55			55.40					
	40	62.05	72.90			61.75					
	44	68.40	79.25			68.10					
	48	74.75	85.60			74.45					
	52	81.10	91.95			80.80					

all dimensions in mm / en millimètre / alle Maße in mm / in millimetri / en milímetros

2) Grip range with recommended POP Avdel installation tools / Plage de serrage avec les outils d'installation POP Avdel recommandées / Klemmbereich mit empfohlenen POP Avdel Verarbeitungsgeräten / Gamma grip con i raccomandati strumenti di installazione POP Avdel / Rango de espesores con las herramientas de colocación recomendadas POP Avdel

NeoBolt® 12851 Series
Lockbolt Fastener

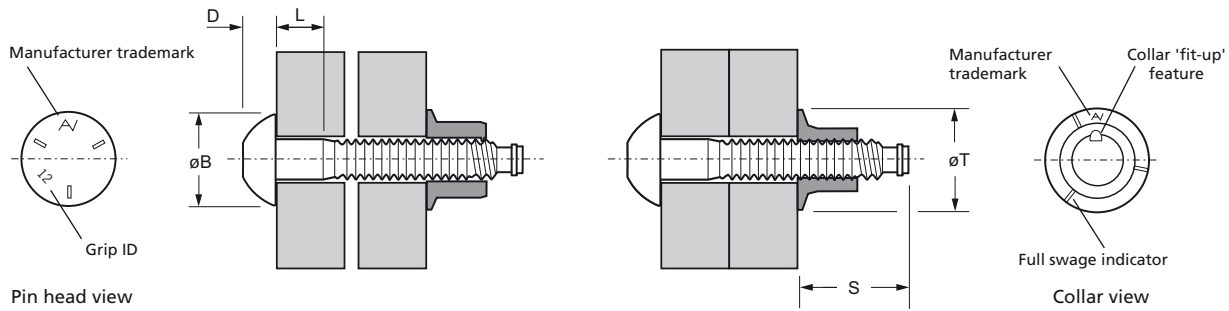

ø nom.	e			L		øB nom.	D nom.	S at grip e max.	øT nom.	Part No/ref		
	ID	e min. ²⁾	e max. ²⁾	min.	max.					Pin	Collar	
16.0 (5/8")	56	87.45	98.30	16.30	17.46	29.00	10.00	e min. = 50.90 e max. = 40.05	31.74	12851-12056	12801-32000	
	60	93.80	104.65							87.15		12851-12060
	64	100.15	111.00							93.50		12851-12064
	68	106.50	117.35							99.85		12851-12068
	72	112.85	123.70							106.20		12851-12072
	76	119.20	130.05							112.55		12851-12076
19.1 (3/4")	4	9.85	16.45	19.60	20.63	35.52	13.02	e min. = 55.37 e max. = 48.77	38.09	12851-12404	12801-32400	
	8	16.20	22.80							4.60		12851-12408
	12	22.55	29.15							10.95		12851-12412
	16	28.90	35.50							17.30		12851-12416
	20	35.25	41.85							23.65		12851-12420
	24	41.60	48.20							30.00		12851-12424
	28	47.95	54.55							36.35		12851-12428
	32	54.30	60.90							42.70		12851-12432
	36	60.65	67.25							49.05		12851-12436
	40	67.00	73.60							55.40		12851-12440
	44	73.35	79.95							61.75		12851-12444
	48	79.70	86.30							68.10		12851-12448
	52	86.05	92.65							74.45		12851-12452
	56	92.40	99.00							80.80		12851-12456
	60	98.75	105.35							87.15		12851-12460
	64	105.10	111.70							93.50		12851-12464
68	111.45	118.05	99.85	12851-12468								
72	117.80	124.40	106.20	12851-12472								
76	124.15	130.75	112.55	12851-12476								
25.4 (1")	8	13.80	25.00	26.00	28.57	46.75	15.63	e min. = 74.01 e max. = 62.81	47.61	12851-13208	12801-33200	
	12	20.15	31.35							10.95		12851-13212
	16	26.50	37.70							17.30		12851-13216
	20	32.85	44.05							23.65		12851-13220
	24	39.20	50.40							30.00		12851-13224
	28	45.55	56.75							36.35		12851-13228
	32	51.90	63.10							42.70		12851-13232
	36	58.25	69.45							49.05		12851-13236
	40	64.60	75.80							55.40		12851-13240
	44	70.95	82.15							61.75		12851-13244
	48	77.30	88.50							68.10		12851-13248
	52	83.65	94.85							74.45		12851-13252
	56	90.00	101.20							80.80		12851-13256
	60	96.35	107.55							87.15		12851-13260
64	102.70	113.90	93.50	12851-13264								
68	109.05	120.25	99.85	12851-13268								
			106.20									

all dimensions in mm / en millimètre / alle Maße in mm / in millimetri / en milímetros

2) Grip range with recommended POP Avdel installation tools / Plage de serrage avec les outils d'installation POP Avdel recommandées / Klemmbereich mit empfohlenen POP Avdel Verarbeitungsgeräten / Gamma grip con i raccomandati strumenti di installazione POP Avdel / Rango de espesores con las herramientas de colocación recomendadas POP Avdel

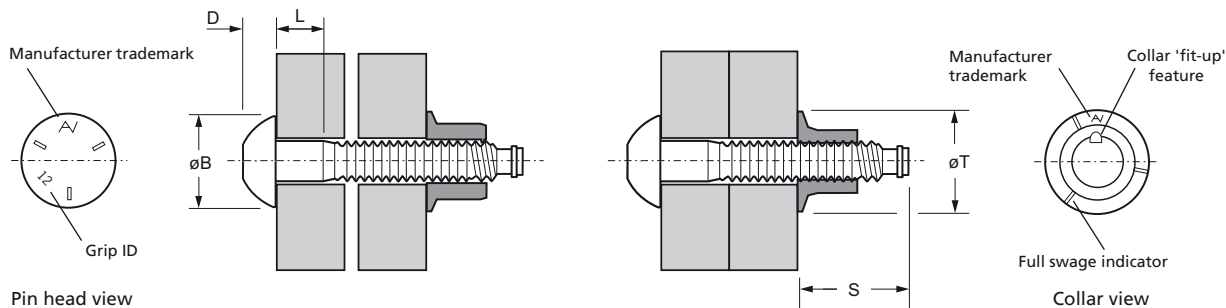

ø nom.	e		L		øB nom.	D nom.	S at grip e max.	øT nom.	Part No/ref		
	ID	e min. ²⁾	e max. ²⁾	min.					max.	Pin	Collar
25.4 (1")	72	115.40	126.60	26.00	28.57	46.75	15.63	47.61	12851-13272	12801-33200	
	76	121.75	132.95								112.55
	80	128.10	139.30								118.90
	84	134.45	145.65								125.25
	88	140.80	152.00								131.60
	92	147.15	158.35								137.95
				144.30					12851-13280		
									12851-13284		
									12851-13288		
									12851-13292		

all dimensions in mm / en millimètre / alle Maße in mm / in millimetri / en milímetros

2) Grip range with recommended POP Avdel installation tools / Plage de serrage avec les outils d'installation POP Avdel recommandés / Klemmbereich mit empfohlenen POP Avdel Verarbeitungsgeräten / Gamma grip con i raccomandati strumenti di installazione POP Avdel / Rango de espesores con las herramientas de colocación recomendadas POP Avdel

ø nom.			
	kN ³⁾	kN ³⁾	kN ³⁾
4.8 (3/16")	12.2	7.4	4.7
6.4 (1/4")	18.3	13.4	8.4
8.0 (5/16")	34.9	24.2	16.0
9.6 (3/8")	46.2	35.1	22.1
12.7 (1/2")	86.2	79.6	57.7
16.0 (5/8")	145.1	126.5	91.7
19.1 (3/4")	187.2	187.3	135.8
25.4 (1")	326.7	339.6	246.2

3) Typical strength values; note that actual joint strength will depend upon joint material type, thickness, etc. and so application testing is always recommended.

Les valeurs typiques de résistance; notez que la résistance actuel de l'assemblage dépend du type de matériau utilisé, épaisseur etc... c'est ainsi qu'il est toujours recommandé de faire des test d'assemblage.

Typische Festigkeitswerte; bitte beachten Sie, dass die tatsächliche Festigkeit von Bauteilmaterial, Materialstärke etc. abhängt - ein Applikationstest ist immer empfohlen.

Valori di resistenza tipici, si noti che la forza congiunta effettiva dipenderà dal tipo di materiale, spessore, ecc e quindi un test delle applicazioni è sempre consigliato.

Valores de resistencia típicos, tenga en cuenta que la fuerza conjunta real dependerá del tipo de material de unión, espesor, etc., y así las pruebas de aplicaciones siempre se recomienda.



English	Français	Deutsch	Italiano	Español
Brazier head	Tête plate	Flachrundkopf	Testa tonda	Cabeza alomada
Pin: Carbon boron steel* Zinc plated Clear trivalent passivated	Tige: Acier* Revêtement zingué Passivation claire trivalente	Bolzen: Stahl* Verzinkt Klar chromatiert, Cr6-frei	Bullone: Acciaio a carbonio* Zincato, Passivazione chiara trivalente	Vástago: Acero al carbono* Zincado Pasivado claro trivalente
Collar: Low carbon steel** Zinc plated Clear trivalent passivated	Bague: Acier bas carbone** Revêtement zingué Passivation claire trivalente	Schließring: Stahl** Verzinkt Klar chromatiert, Cr6-frei	Collare: Acciaio a basso tenore di carbonio** Zincato, Passivazione chiara trivalente	Collar: Acero bajo en carbono** Zincado Pasivado claro trivalente

*: SAE 10B21 EN 10263-4 23MnB4 **: SAE 1008 EN 10263-2 C8C

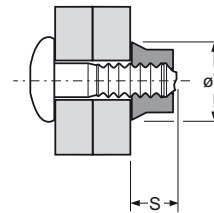
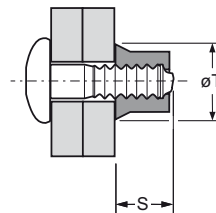
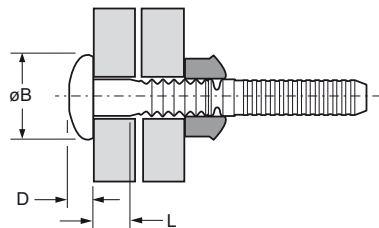

Full Collar
Schließring Standard
Bague Standard
Collare Standard
Collar Estándar

Half Collar
Schließring flach
Bague courte
Collare ribassato
Medio Collar

Flanged Collar
Schließring mit Bund
Bague à embase
Collare flangiato
Collar con Ala

Ø	w. Full Collar ¹⁾		L	ØB	D	Part No/ref	Part No/ref		Part No/ref			
	min.	max.					Full Collar	Half Collar ¹⁾	Flanged Collar ²⁾			
nom.			nom.	max.	max.	Pin	S max.	ØT max.	S max.	ØT max.	U ²⁾ nom.	
4.8 (3/16")	1.57	4.75	1.57	5.0	10.1	3.4	02621-70602	02662-70600	02682-70600	02615-70600 10.2 9.9 0.76		
	3.18	6.35	3.18				02621-70603					
	4.75	7.92	4.75				02621-70604					
	6.35	9.53	6.35				02621-70605					
	7.92	11.10	7.92				02621-70606					
	9.53	12.70	9.53				02621-70607					
	11.10	14.27	11.10				02621-70608					
	12.70	15.88	12.70				02621-70609					
	14.27	17.45	14.27				02621-70610					
	15.88	19.05	15.88				02621-70611					
	17.45	20.62	17.45				02621-70612					
	19.05	22.23	19.05				02621-70613					
	20.62	23.80	20.62				02621-70614					
	22.23	25.40	22.23				02621-70615					
	23.80	26.97	23.80				02621-70616					
	25.40	28.58	25.40				02621-70617					
26.97	30.15	26.97	02621-70618									
28.58	31.75	28.58	02621-70619									
30.15	33.32	30.15	02621-70620									

all dimensions in mm / en millimètre / alle Maße in mm / in millimetri / en milímetros

1) & 2) see page 30 / voir page 30 / siehe Seite 30 / vedi pagina 30 / ver Pág. 30

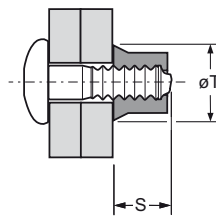
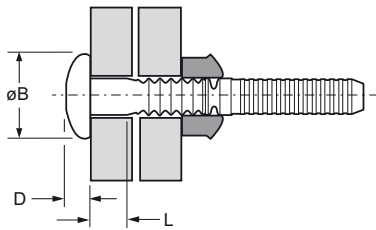

Full Collar

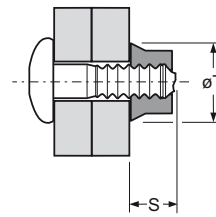

Half Collar

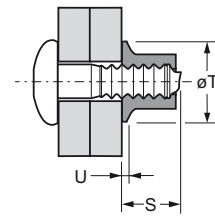

Flanged Collar

Ø nom.	w. Full Collar ¹⁾		L nom.	ØB max.	D max.	Part No/ref Pin	Part No/ref Full Collar		Part No/ref Half Collar ¹⁾		Part No/ref Flanged Collar ²⁾				
	min.	max.					S max.	ØT max.	S max.	ØT max.	S max.	ØT max.	U ²⁾ nom.		
6.4 (1/4")	1.57	4.75	6.6	1.57	13.4	4.1	02621-70802	02662-70800	12.2	10.6	02682-70800	13.2	13.1	0.94	
	3.18	6.35		3.18											02621-70803
	4.75	7.92		4.75											02621-70804
	6.35	9.53		6.35											02621-70805
	7.92	11.10		7.92											02621-70806
	9.53	12.70		9.53											02621-70807
	11.10	14.27		11.10											02621-70808
	12.70	15.88		12.70											02621-70809
	14.27	17.45		14.27											02621-70810
	15.88	19.05		15.88											02621-70811
	17.45	20.62		17.45											02621-70812
	19.05	22.23		19.05											02621-70813
	20.62	23.80		20.62											02621-70814
	22.23	25.40		22.23											02621-70815
8.0 (5/16")	3.18	9.53	8.2	3.18	16.7	5.5	02621-71004	02662-71000	15.5	13.3	02682-71000	16.8	16.3	1.22	
	6.35	12.70		6.35											02621-71006
	9.53	15.88		9.53											02621-71008
	12.70	19.05		12.70											02621-71010
	15.88	22.23		15.88											02621-71012
	19.05	25.40		19.05											02621-71014
	22.23	28.58		22.23											02621-71016
	25.40	31.75		25.40											02621-71018
	28.58	34.93		28.58											02621-71020
	31.75	38.10		31.75											02621-71022
	34.93	41.28		34.93											02621-71024
	38.10	44.45		38.10											02621-71026
	41.28	47.63		41.28											02621-71028
	44.45	50.80		44.45											02621-71030
47.63	53.98	47.63	02621-71032												
9.6 (3/8")	3.18	9.53	9.8	3.18	20.1	6.7	02621-71204	02662-71200	18.6	15.5	02682-71200	20.0	20.0	1.42	
	6.35	12.70		6.35											02621-71206
	9.53	15.88		9.53											02621-71208
	12.70	19.05		12.70											02621-71210

all dimensions in mm / en millimètre / alle Maße in mm / in millimetri / en milímetros

1) & 2) see page 30 / voir page 30 / siehe Seite 30 / vedi pagina 30 / ver Pág. 30

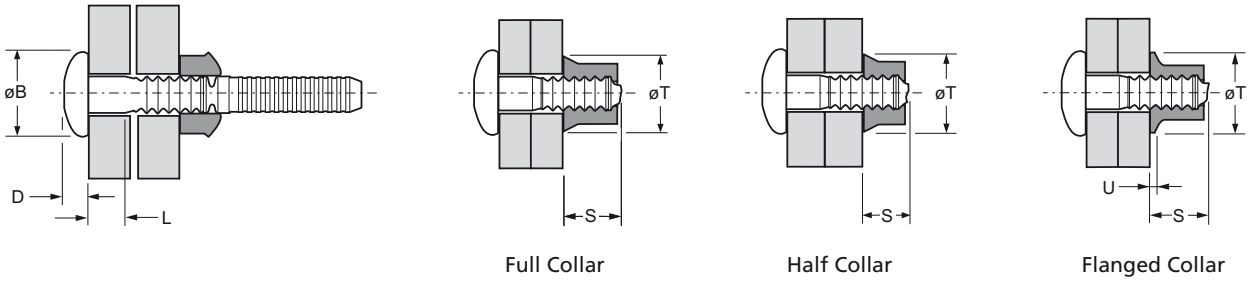

ø nom.	w. Full Collar ¹⁾		L nom.	øB max.	D max.	Part No/ref Pin	Part No/ref Full Collar		Part No/ref Half Collar ¹⁾		Part No/ref Flanged Collar ²⁾		
	min.	max.					S max.	øT max.	S max.	øT max.	S max.	øT max.	U ²⁾ nom.
9.6 (3/8")	15.88	22.23	15.88	20.1	6.7	02621-71212	02662-71200	18.6	15.5	02682-71200	20.0	20.0	1.42
	19.05	25.40	19.05			02621-71214							
	22.23	28.58	22.23			02621-71216							
	25.40	31.75	25.40			02621-71218							
	28.58	34.93	28.58			02621-71220							
	31.75	38.10	31.75			02621-71222							
	34.93	41.28	34.93			02621-71224							
	38.10	44.45	38.10			02621-71226							
	41.28	47.63	41.28			02621-71228							
	44.45	50.80	44.45			02621-71230							
	47.63	53.98	47.63			02621-71232							

all dimensions in mm / en millimètre / alle Maße in mm / in millimetri / en milímetros

1) Half collars increase the grip range to that of the next longest pin. Maximum grip increases by 1.57 mm for 4.8 mm and 6.4 mm fasteners and 3.18 mm for 8.0 mm and 9.6 mm fasteners.

Avec une bague courte, la plage de serrage maximale est équivalente à celle de l'Avdelok de longueur immédiatement supérieure. La plage de serrage augmente de 1.57 mm pour tiges de 4.8 mm et 6.4 mm, et de 3.18 mm pour tiges de 8.0 mm et 9.6 mm.

Die Verwendung von flachen Schließringen erhöht den Klemmbereich auf den des nächstlängeren Bolzens. Der maximale Klemmbereich erhöht sich um 1,6 mm für ø 4,8 mm und ø 6,4 mm Bolzen und 3,2 mm für ø 8,0 mm und ø 9,6 mm Bolzen.

Utilizzando i collari ribassati lo spessore serrabile aumenta, ed è uguale a quello massimo del bullone di misura superiore. Il massimo spessore serrabile aumenta di 1.57 mm per i bulloni da 4.8 mm e 6.4 mm e di 3.18 mm per i bulloni da 8.0 mm e 9.6 mm.

El empleo de medio collar incrementa el máx. espesor a remachar al de la siguiente toma. El máximo espesor a remachar por uso de medio collar es de 1,57 mm para diámetros de 4,8 y 6,4 mm y de 3,18 mm para diámetros de 8 y 9,6 mm.



2) Flanged collars are used in applications where the hole on the collar side of the application is oversize or is slotted for alignment purposes. To determine what length of pin is required, add dimension U to the thickness of material being fastened.

Avec une bague à embase, la plage de serrage est diminuée de la valeur de la cote U.

Schließringe mit Bund werden in Anwendungen benötigt, wo das Bohrloch auf der Schließringseite übergroß oder länglich ist. Um den richtigen Bolzen zu bestimmen, addieren Sie das Maß U zu der zu verbindenden Materialstärke hinzu.

Utilizzando i collari flangiati la dimensione „U“ deve essere aggiunta allo spessore da serrare per determinare il tipo di bullone adatto.

Utilizar collar con ala cuando en la aplicación el barreno está sobredimensionado o es ranurado para propósitos de alineación. Para calcular la referencia de perno es necesario añadir la cota U al espesor de la aplicación.

ø nom.	 kN ³⁾	 kN ³⁾
4.8	8.63	7.34
6.4	14.73	13.35
8.0	22.38	21.81
9.6	32.08	28.93

3) These figures represent minimum fastener shear and tensile strength values with the use of a full or flanged collar. When using half collars tension is reduced to approximately 45 %.

Cette valeurs représentent minimum résistances au cisaillement et à la traction avec l'usage d'une bague standard ou à embase. Avec l'usage des bagues courtes la résistance à la traction se diminue à env. 45 %.

Diese Werte repräsentieren Minimum Scher- und Zugfestigkeiten der Verbindung unter Verwendung von Schließringen Standard oder mit Bund. Bei Verwendung von flachen Schließringen reduziert sich die Zugfestigkeit auf ca. 45 %.

I dati si riferiscono a bulloni installati con collari standard o flangiato, utilizzando collari ribassati i valori di trazione diminuiscono del 45 % circa, i valori di taglio rimangono invariati. I dati indicati in tabella sono minimi.

La figura representa los valores mínimos de resistencia a la cortadura y tracción cuando se utiliza collar estándar o con ala. Cuando se utiliza medio collar se reducen aproximadamente en un 45 %.

Steel Avdelok pins typically offer comparable performance values to similar diameter metric property class 5.8 threaded products.

Les tiges Avdelok acier offrent des performances comparables à celles d'un boulon métrique de classe 5.8 et de diamètre similaire.

Avdelok Bolzen aus Stahl bieten normalerweise Festigkeitswerte, die mit denen eines metrischen Gewindeproduktes der Festigkeitsklasse 5.8 mit ähnlichem Durchmesser vergleichbar sind.

I bulloni Avdelok in acciaio normalmente offrono valori prestazionali comparabili a prodotti filettati metrici di pari diametro in classe di resistenza 5.8.

Los pernos Avdelok de acero normalmente ofrecen resistencias comparables a la de un tornillo métrico, de clase 5.8, con un diámetro similar.



English	Français	Deutsch	Italiano	Español
90° Countersunk	90° Tête fraisée	90° Senkkopf	90° Testa svasata	90° Cabeza avellanada
Pin: Carbon boron steel* Zinc plated Clear trivalent passivated	Tige: Acier* Revêtement zingué Passivation claire trivalente	Bolzen: Stahl* Verzinkt Klar chromatiert, Cr6-frei	Bullone: Acciaio a carbonio* Zincato, Passivazione chiara trivalente	Vástago: Acero al carbono* Zincado Pasivado claro trivalente
Collar: Low carbon steel** Zinc plated Clear trivalent passivated	Bague: Acier bas carbone** Revêtement zingué Passivation claire trivalente	Schließring: Stahl** Verzinkt Klar chromatiert, Cr6-frei	Collare: Acciaio a basso tenore di carbonio** Zincato, Passivazione chiara trivalente	Collar: Acero bajo en carbono** Zincado Pasivado claro trivalente

*: SAE 10B21 EN 10263-4 23MnB4 **: SAE 1008 EN 10263-2 C8C

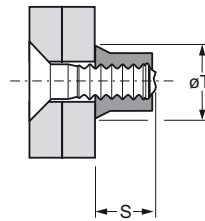
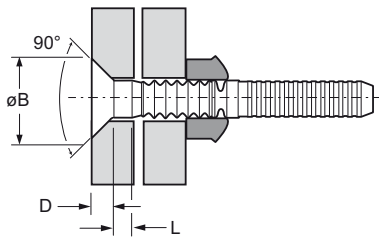

Full Collar
Schließring Standard
Bague Standard
Collare Standard
Collar Estándar

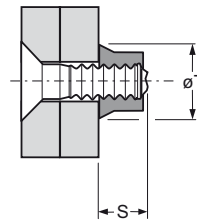

Half Collar
Schließring flach
Bague courte
Collare ribassato
Medio Collar

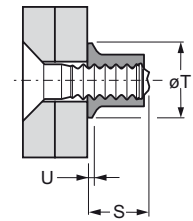

Flanged Collar
Schließring mit Bund
Bague à embase
Collare flangiato
Collar con Ala

ø	w. Full Collar ¹⁾		L	øB	D	Part No/ref	Part No/ref		Part No/ref			
	min.	max.					Full Collar	Half Collar ¹⁾	Flanged Collar ²⁾			
nom.			nom.	max.	max.	Pin	S max.	øT max.	S max.	øT max.	U ²⁾ nom.	
4.8 (3/16")	3.18	6.35	3.18	5.0	8.9	2.2	02622-70603	02662-70600	9.4	8.0	02682-70600	02615-70600
	4.75	7.92	4.75									
	6.35	9.53	6.35									
	7.92	11.10	7.92									
	9.53	12.70	9.53									
	11.10	14.27	11.10									
	12.70	15.88	12.70									
	14.27	17.45	14.27									
	15.88	19.05	15.88									
	17.45	20.62	17.45									
	19.05	22.23	19.05									
	20.62	23.80	20.62									
	22.23	25.40	22.23									
	23.80	26.97	23.80									
	25.40	28.58	25.40									
	26.97	30.15	26.97									
28.58	31.75	28.58										
30.15	33.32	30.15										

all dimensions in mm / en millimètre / alle Maße in mm / in millimetri / en milímetros

1) & 2) see page 33 / voir page 33 / siehe Seite 33 / vedi pagina 33 / ver Pág. 33

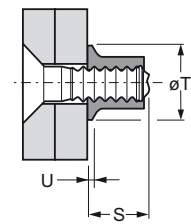
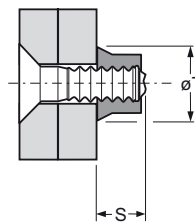
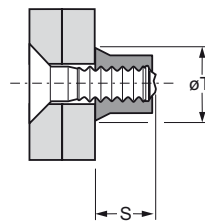
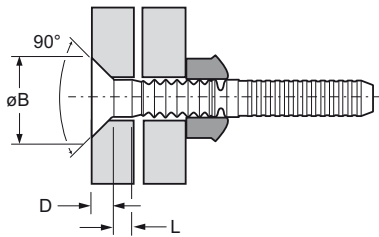

Full Collar

Half Collar

Flanged Collar

Ø nom.	w. Full Collar ¹⁾		L nom.	ØB max.	D max.	Part No/ref Pin	Part No/ref Full Collar		Part No/ref Half Collar ¹⁾		Part No/ref Flanged Collar ²⁾			
	min.	max.					S max.	ØT max.	S max.	ØT max.	S max.	ØT max.	U ²⁾ nom.	
6.4 (1/4")	3.18	6.35	6.6	3.18	11.9	2.9	02622-70803	02662-70800	02682-70800	02615-70800	13.2	13.1	0.94	
	4.75	7.92		4.75										02622-70804
	6.35	9.53		6.35										02622-70805
	7.92	11.10		7.92										02622-70806
	9.53	12.70		9.53										02622-70807
	11.10	14.27		11.10										02622-70808
	12.70	15.88		12.70										02622-70809
	14.27	17.45		14.27										02622-70810
	15.88	19.05		15.88										02622-70811
	17.45	20.62		17.45										02622-70812
	19.05	22.23		19.05										02622-70813
	20.62	23.80		20.62										02622-70814
	22.23	25.40		22.23										02622-70815
	23.80	26.97		23.80										02622-70816
26.97	30.15	26.97	02622-70818											
30.15	33.32	30.15	02622-70820											
8.0 (5/16")	3.18	9.53	8.2	3.18	14.8	3.6	02622-71004	02662-71000	02682-71000	02615-71000	16.8	16.3	1.22	
	6.35	12.70		6.35										02622-71006
	9.53	15.88		9.53										02622-71008
	12.70	19.05		12.70										02622-71010
	15.88	22.23		15.88										02622-71012
	19.05	25.40		19.05										02622-71014
	22.23	28.58		22.23										02622-71016
	25.40	31.75		25.40										02622-71018
	28.58	34.93		28.58										02622-71020
	31.75	38.10		31.75										02622-71022
	34.93	41.28		34.93										02622-71024
	38.10	44.45		38.10										02622-71026
	41.28	47.63		41.28										02622-71028
	44.45	50.80		44.45										02622-71030
47.63	53.98	47.63	02622-71032											
9.6 (3/8")	6.35	12.70	9.8	6.35	17.7	4.4	02622-71206	02662-71200	02682-71200	02615-71200	20.0	20.0	1.42	
	9.53	15.88		9.53										02622-71208
	12.70	19.05		12.70										02622-71210
	15.88	22.23		15.88										02622-71212
	19.05	25.40		19.05										02622-71214
	22.23	28.58		22.23										02622-71216

all dimensions in mm / en millimètre / alle Maße in mm / in millimetri / en milímetros
1) & 2) see page 33 / voir page 33 / siehe Seite 33 / vedi pagina 33 / ver Pág. 33

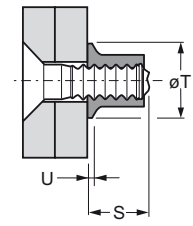
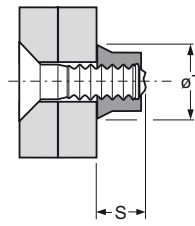
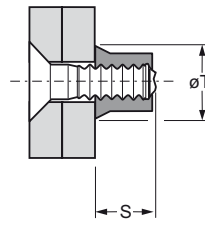
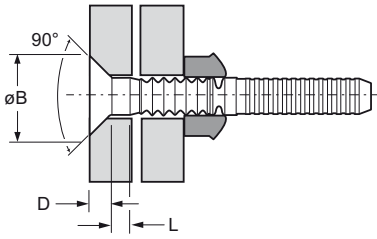

Full Collar

Half Collar

Flanged Collar

Ø	w. Full Collar ¹⁾		L	ØB	D	Part No/ref	Part No/ref		Part No/ref				
	min.	max.					Full Collar	Half Collar ¹⁾	Flanged Collar ²⁾				
nom.			nom.	max.	max.	Pin	S max.	ØT max.	S max.	ØT max.	S max.	ØT max.	U ²⁾ nom.
9.6 (3/8")	25.40	31.75	9.8	25.40	17.7	4.4	02622-71218	02662-71200	02682-71200	20.0	20.0	1.42	
	28.58	34.93		02622-71220									
	31.75	38.10		02622-71222									
	34.93	41.28		02622-71224									
	38.10	44.45		02622-71226									
	41.28	47.63		02622-71228									
	44.45	50.80		02622-71230									
	47.63	53.98		02622-71232									

all dimensions in mm / en millimètre / alle Maße in mm / in millimetri / en milímetros

1) Half collars increase the grip range to that of the next longest pin. Maximum grip increases by 1.57 mm for 4.8 mm and 6.4 mm fasteners and 3.18 mm for 8.0 mm and 9.6 mm fasteners.

Avec une bague courte, la plage de serrage maximale est équivalente à celle de l'Avdelok de longueur immédiatement supérieure. La plage de serrage augmente de 1.57 mm pour tiges de 4.8 mm et 6.4 mm, et de 3.18 mm pour tiges de 8.0 mm et 9.6 mm.

Die Verwendung von flachen Schließringen erhöht den Klemmbereich auf den des nächstlängeren Bolzens. Der maximale Klemmbereich erhöht sich um 1,6 mm für Ø 4,8 mm und Ø 6,4 mm Bolzen und 3,2 mm für Ø 8,0 mm und Ø 9,6 mm Bolzen.

Utilizzando i collari ribassati lo spessore serrabile aumenta, ed è uguale a quello massimo del bullone di misura superiore. Il massimo spessore serrabile aumenta di 1.57 mm per i bulloni da 4.8 mm e 6.4 mm e di 3.18 mm per i bulloni da 8.0 mm e 9.6 mm.

El empleo de medio collar incrementa el máx. espesor a remachar al de la siguiente toma. El máximo espesor a remachar por uso de medio collar es de 1,57 mm para diámetros de 4,8 y 6,4 mm y de 3,18 mm para diámetros de 8 y 9,6 mm.



2) Flanged collars are used in applications where the hole on the collar side of the application is oversize or is slotted for alignment purposes. To determine what length of pin is required, add dimension U to the thickness of material being fastened.

Avec une bague à embase, la plage de serrage est diminuée de la valeur de la cote U.

Schließringe mit Bund werden in Anwendungen benötigt, wo das Bohrloch auf der Schließringseite übergroß oder länglich ist. Um den richtigen Bolzen zu bestimmen, addieren Sie das Maß U zu der zu verbindenden Materialstärke hinzu.

Utilizzando i collari flangiati la dimensione „U“ deve essere aggiunta allo spessore da serrare per determinare il tipo di bullone adatto.

Utilizar collar con ala cuando en la aplicación el barreno está sobredimensionado o es ranurado para propósitos de alineación. Para calcular la referencia de perno es necesario añadir la cota U al espesor de la aplicación.

Ø		
nom.	kN ³⁾	kN ³⁾
4.8	8.63	7.34
6.4	14.73	13.35
8.0	22.38	21.81
9.6	32.08	28.93

3) These figures represent minimum fastener shear and tensile strength values with the use of a full or flanged collar. When using half collars tension is reduced to approximately 45 %.

Cette valeurs représentent minimum résistances au cisaillement et à la traction avec l'usage d'une bague standard ou à embase. Avec l'usage des bagues courtes la résistance à la traction se diminue à env. 45 %.

Diese Werte repräsentieren Minimum Scher- und Zugfestigkeiten der Verbindung unter Verwendung von Schließringen Standard oder mit Bund. Bei Verwendung von flachen Schließringen reduziert sich die Zugfestigkeit auf ca. 45 %.

I dati si riferiscono a bulloni installati con collari standard o flangiato, utilizzando collari ribassati i valori di trazione diminuiscono del 45 % circa, i valori di taglio rimangono invariati. I dati indicati in tabella sono minimi.

La figura representa los valores mínimos de resistencia a la cortadura y tracción cuando se utiliza collar estándar o con ala. Cuando se utiliza medio collar se reducen aproximadamente en un 45 %.

Steel Avdelok pins typically offer comparable performance values to similar diameter metric property class 5.8 threaded products. Les tiges Avdelok acier offrent des performances comparables à celles d'un boulon métrique de classe 5.8 et de diamètre similaire. Avdelok Bolzen aus Stahl bieten normalerweise Festigkeitswerte, die mit denen eines metrischen Gewindeproduktes der Festigkeitsklasse 5.8 mit ähnlichem Durchmesser vergleichbar sind.

I bulloni Avdelok in acciaio normalmente offrono valori prestazionali comparabili a prodotti filettati metrici di pari diametro in classe di resistenza 5.8.

Los pernos Avdelok de acero normalmente ofrecen resistencias comparables a la de un tornillo métrico, de clase 5.8, con un diámetro similar.



English	Français	Deutsch	Italiano	Español
Truss head	Tête large	Flachrundkopf groß	Testa larga	Cabeza alomada de perfil bajo
Pin: Carbon boron steel* Zinc plated Clear trivalent passivated	Tige: Acier* Revêtement zingué Passivation claire trivalente	Bolzen: Stahl* Verzinkt Klar chromatiert, Cr6-frei	Bullone: Acciaio a carbonio* Zincato, Passivazione chiara trivalente	Vástago: Acero al carbono* Zincado Pasivado claro trivalente
Collar: Low carbon steel** Zinc plated Clear trivalent passivated	Bague: Acier bas carbone** Revêtement zingué Passivation claire trivalente	Schließring: Stahl** Verzinkt Klar chromatiert, Cr6-frei	Collare: Acciaio a basso tenore di carbonio** Zincato, Passivazione chiara trivalente	Collar: Acero bajo en carbono** Zincado Pasivado claro trivalente

*: SAE 10B21 EN 10263-4 23MnB4 **: SAE 1008 EN 10263-2 C8C

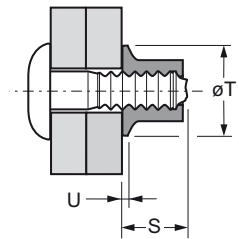
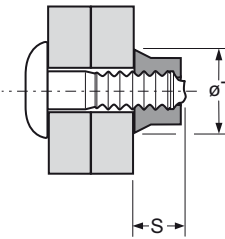
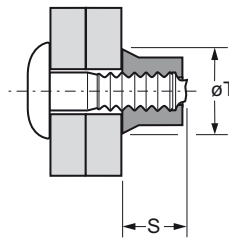
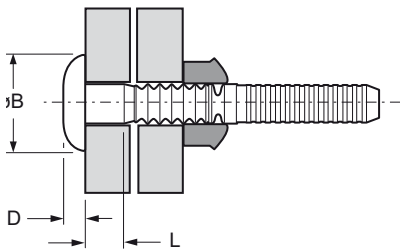

Full Collar
Schließring Standard
Bague Standard
Collare Standard
Collar Estándar

Half Collar
Schließring flach
Bague courte
Collare ribassato
Medio Collar

Flanged Collar
Schließring mit Bund
Bague à embase
Collare flangiato
Collar con Ala

ø nom.	w. Full Collar ¹⁾		L nom.	øB max.	D max.	Part No/ref Pin	Part No/ref Full Collar		Part No/ref Half Collar ¹⁾		Part No/ref Flanged Collar ²⁾		
	min.	max.					S max.	øT max.	S max.	øT max.	S max.	øT max.	U ²⁾ nom.
4.8 (3/16")	1.57	4.75	1.57	12.0	2.2	02624-70602	02662-70600	9.4	8.0	02682-70600	10.2	9.9	0.76
	3.18	6.35	3.18			02624-70603							
	4.75	7.92	4.75			02624-70604							
	6.35	9.53	6.35			02624-70605							
	7.92	11.10	7.92			02624-70606							
	9.53	12.70	9.53			02624-70607							
	11.10	14.27	11.10			02624-70608							
	12.70	15.88	12.70			02624-70609							
	14.27	17.45	14.27			02624-70610							
	15.88	19.05	15.88			02624-70611							
	17.45	20.62	17.45			02624-70612							
	19.05	22.23	19.05			02624-70613							
	20.62	23.80	20.62			02624-70614							
	22.23	25.40	22.23			02624-70615							
	23.80	26.97	23.80			02624-70616							
	25.40	28.58	25.40			02624-70617							
26.97	30.15	26.97	02624-70618										
28.58	31.75	28.58	02624-70619										
30.15	33.32	30.15	02624-70620										

all dimensions in mm / en millimètre / alle Maße in mm / in millimetri / en milímetros

1) & 2) see page 36 / voir page 36 / siehe Seite 36 / vedi pagina 36 / ver Pág. 36

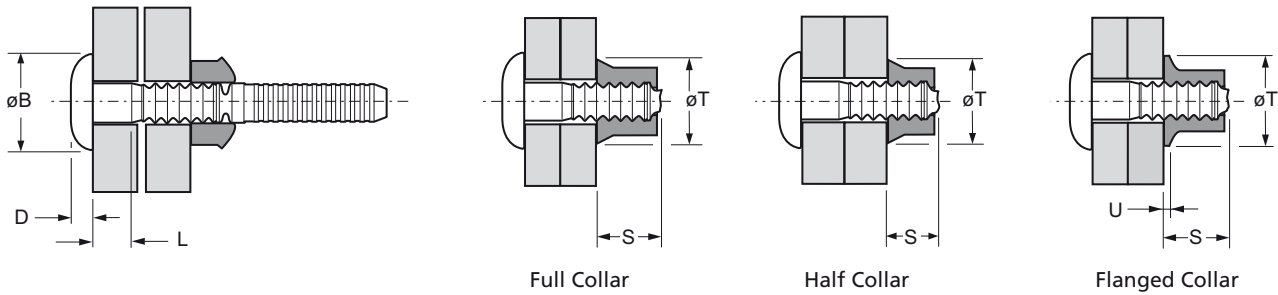

ø nom.	w. Full Collar ¹⁾		L nom.	øB max.	D max.	Part No/ref Pin	Part No/ref Full Collar		Part No/ref Half Collar ¹⁾		Part No/ref Flanged Collar ²⁾		
	min.	max.					S max.	øT max.	S max.	øT max.	S max.	øT max.	U ²⁾ nom.
6.4 (1/4")	1.57	4.75	1.57	15.2	2.8	02624-70802	02662-70800	12.2 10.6	02682-70800	10.7 10.6	02615-70800 13.2 13.1 0.94		
	3.18	6.35	3.18			02624-70803							
	4.75	7.92	4.75			02624-70804							
	6.35	9.53	6.35			02624-70805							
	7.92	11.10	7.92			02624-70806							
	9.53	12.70	9.53			02624-70807							
	11.10	14.27	11.10			02624-70808							
	12.70	15.88	12.70			02624-70809							
	14.27	17.45	14.27			02624-70810							
	15.88	19.05	15.88			02624-70811							
	17.45	20.62	17.45			02624-70812							
	19.05	22.23	19.05			02624-70813							
	20.62	23.80	20.62			02624-70814							
	22.23	25.40	22.23			02624-70815							
	23.80	26.97	23.80			02624-70816							
	26.97	30.15	26.97			02624-70818							
30.15	33.32	30.15	02624-70820										
8.0 (5/16")	3.18	9.53	3.18	19.9	3.6	02624-71004	02662-71000	15.5 13.3	02682-71000	12.5 13.3	02615-71000 16.8 16.3 1.22		
	6.35	12.70	6.35			02624-71006							
	9.53	15.88	9.53			02624-71008							
	12.70	19.05	12.70			02624-71010							
	15.88	22.23	15.88			02624-71012							
	19.05	25.40	19.05			02624-71014							
	22.23	28.58	22.23			02624-71016							
	25.40	31.75	25.40			02624-71018							
	28.58	34.93	28.58			02624-71020							
	31.75	38.10	31.75			02624-71022							
	34.93	41.28	34.93			02624-71024							
	38.10	44.45	38.10			02624-71026							
	41.28	47.63	41.28			02624-71028							
	44.45	50.80	44.45			02624-71030							
47.63	53.98	47.63	02624-71032										
9.6 (3/8")	3.18	9.53	3.18	23.5	4.1	02624-71204	02662-71200	18.6 15.5	02682-71200	15.5 15.5	02615-71200 20.0 20.0 1.42		
	6.35	12.70	6.35			02624-71206							
	9.53	15.88	9.53			02624-71208							
	12.70	19.05	12.70			02624-71210							
	15.88	22.23	15.88			02624-71212							

all dimensions in mm / en millimètre / alle Maße in mm / in millimetri / en milímetros

1) & 2) see page 36 / voir page 36 / siehe Seite 36 / vedi pagina 36 / ver Pág. 36

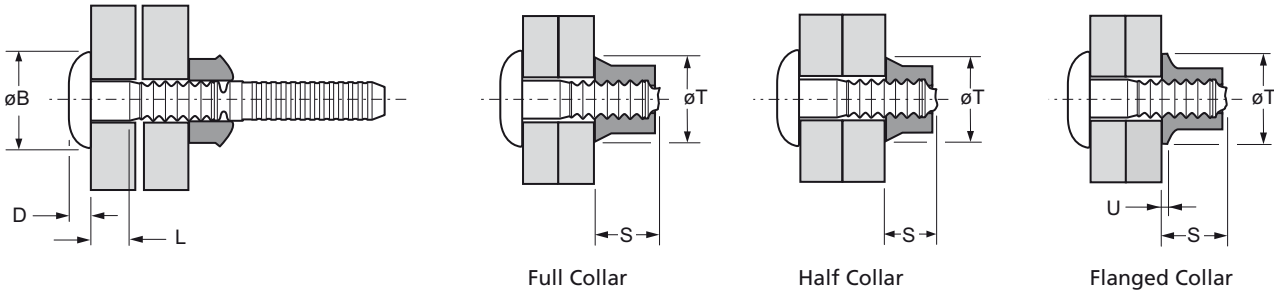

Ø nom.	w. Full Collar ¹⁾		L nom.	ØB max.	D max.	Part No/ref Pin	Part No/ref Full Collar		Part No/ref Half Collar ¹⁾		Part No/ref Flanged Collar ²⁾		
	min.	max.					S max.	ØT max.	S max.	ØT max.	S max.	ØT max.	U ²⁾ nom.
9.6 (3/8")	19.05	25.40	19.05	23.5	4.1	02624-71214	02662-71200	18.6	15.5	02682-71200	20.0	20.0	1.42
	22.23	28.58	22.23			02624-71216							
	25.40	31.75	25.40			02624-71218							
	28.58	34.93	28.58			02624-71220							
	31.75	38.10	31.75			02624-71222							
	34.93	41.28	34.93			02624-71224							
	38.10	44.45	38.10			02624-71226							
	41.28	47.63	41.28			02624-71228							
	44.45	50.80	44.45			02624-71230							
	47.63	53.98	47.63			02624-71232							

all dimensions in mm / en millimètre / alle Maße in mm / in millimetri / en milímetros

1) Half collars increase the grip range to that of the next longest pin. Maximum grip increases by 1.57 mm for 4.8 mm and 6.4 mm fasteners and 3.18 mm for 8.0 mm and 9.6 mm fasteners.

Avec une bague courte, la plage de serrage maximale est équivalente à celle de l'Avdelok de longueur immédiatement supérieure. La plage de serrage augmente de 1.57 mm pour tiges de 4.8 mm et 6.4 mm, et de 3.18 mm pour tiges de 8.0 mm et 9.6 mm.

Die Verwendung von flachen Schließringen erhöht den Klemmbereich auf den des nächstlängeren Bolzens. Der maximale Klemmbereich erhöht sich um 1,6 mm für Ø 4,8 mm und Ø 6,4 mm Bolzen und 3,2 mm für Ø 8,0 mm und Ø 9,6 mm Bolzen.

Utilizzando i collari ribassati lo spessore serrabile aumenta, ed è uguale a quello massimo del bullone di misura superiore. Il massimo spessore serrabile aumenta di 1.57 mm per i bulloni da 4.8 mm e 6.4 mm e di 3.18 mm per i bulloni da 8.0 mm e 9.6 mm.

El empleo de medio collar incrementa el máx. espesor a remachar al de la siguiente toma. El máximo espesor a remachar por uso de medio collar es de 1,57 mm para diámetros de 4,8 y 6,4 mm y de 3,18 mm para diámetros de 8 y 9,6 mm.



2) Flanged collars are used in applications where the hole on the collar side of the application is oversized or is slotted for alignment purposes. To determine what length of pin is required, add dimension U to the thickness of material being fastened.

Avec une bague à embase, la plage de serrage est diminuée de la valeur de la cote U.

Schließringe mit Bund werden in Anwendungen benötigt, wo das Bohrloch auf der Schließringseite übergroß oder länglich ist. Um den richtigen Bolzen zu bestimmen, addieren Sie das Maß U zu der zu verbindenden Materialstärke hinzu.

Utilizzando i collari flangiati la dimensione „U“ deve essere aggiunta allo spessore da serrare per determinare il tipo di bullone adatto.

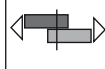
Utilizar collar con ala cuando en la aplicación el barreno está sobredimensionado o es ranurado para propósitos de alineación. Para calcular la referencia de perno es necesario añadir la cota U al espesor de la aplicación.

Ø nom.	 kN ³⁾	 kN ³⁾
4.8	8.63	7.34
6.4	14.73	13.35
8.0	22.38	21.81
9.6	32.08	28.93

3) These figures represent minimum fastener shear and tensile strength values with the use of a full or flanged collar. When using half collars tension is reduced to approximately 45 %.

Cette valeurs représentent minimum résistances au cisaillement et à la traction avec l'usage d'une bague standard ou à embase. Avec l'usage des bagues courtes la résistance à la traction se diminue à env. 45 %.

Diese Werte repräsentieren Minimum Scher- und Zugfestigkeiten der Verbindung unter Verwendung von Schließringen Standard oder mit Bund. Bei Verwendung von flachen Schließringen reduziert sich die Zugfestigkeit auf ca. 45 %.

I dati si riferiscono a bulloni installati con collari standard o flangiato, utilizzando collari ribassati i valori di trazione diminuiscono del 45 % circa, i valori di taglio rimangono invariati. I dati indicati in tabella sono minimi.

La figura representa los valores mínimos de resistencia a la cortadura y tracción cuando se utiliza collar estándar o con ala. Cuando se utiliza medio collar se reducen aproximadamente en un 45 %.

Steel Avdelok pins typically offer comparable performance values to similar diameter metric property class 5.8 threaded products. Les tiges Avdelok acier offrent des performances comparables à celles d'un boulon métrique de classe 5.8 et de diamètre similaire. Avdelok Bolzen aus Stahl bieten normalerweise Festigkeitswerte, die mit denen eines metrischen Gewindeproduktes der Festigkeitsklasse 5.8 mit ähnlichem Durchmesser vergleichbar sind.

I bulloni Avdelok in acciaio normalmente offrono valori prestazionali comparabili a prodotti filettati metrici di pari diametro in classe di resistenza 5.8.

Los pernos Avdelok de acero normalmente ofrecen resistencias comparables a la de un tornillo métrico, de clase 5.8, con un diámetro similar.



English	Français	Deutsch	Italiano	Español
Brazier head	Tête plate	Flachrundkopf	Testa tonda	Cabeza alomada
Pin: Stainless steel* natural	Tige: Inox* Brut	Bolzen: Edelstahl* Blank	Bullone: Acciaio inox * Nessuna finitura	Vástago: Acero inoxidable* Natural
Collar: Stainless steel** Zinc plated Clear trivalent passivated	Bague: Inox** Revêtement zingué Passivation claire trivalente	Schließring: Edelstahl** Verzinkt Klar chromatiert, Cr6-frei	Collare: Acciaio inox** Zincato Passivazione chiara trivalente	Collar: Acero inoxidable** Zincado Pasivado claro trivalente

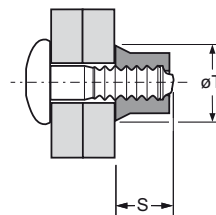
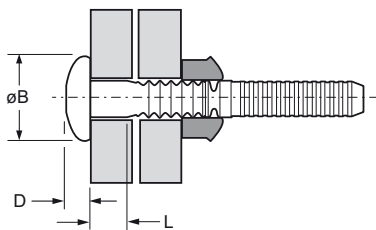

*: AISI 304Cu, EN 10263-5, X3CrNiCu18-9-4 **: AISI 430, EN 10263-5 X6Cr17

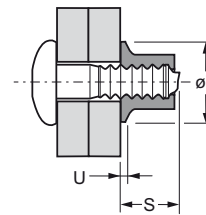

Full Collar
Schließring Standard
Bague Standard
Collare Standard
Collar Estándar



Flanged Collar
Schließring mit Bund
Bague à embase
Collare flangiato
Collar con Ala

Ø nom.	 w. Full Collar			L nom.	ØB max.	D max.	Part No/ref Pin	Part No/ref Full Collar		Part No/ref Flanged Collar ¹⁾		
	min.	max.						S max.	ØT max.	S max.	ØT max.	U ¹⁾ nom.
4.8 (3/16")	1.57	4.75	5.0	1.57	10.0	3.4	02691-00602	02605-70600	9.4	8.0	02648-70600	
	3.18	6.35		3.18			02691-00603					
	4.75	7.92		4.75			02691-00604					
	6.35	9.53		6.35			02691-00605					
	7.92	11.10		7.92			02691-00606					
	9.53	12.70		9.53			02691-00607					
	11.10	14.27		11.10			02691-00608					
	12.70	15.88		12.70			02691-00609					
	14.27	17.45		14.27			02691-00610					
	15.88	19.05		15.88			02691-00611					
	17.45	20.62		17.45			02691-00612					
	19.05	22.23		19.05			02691-00613					
	20.62	23.80		20.62			02691-00614					
	22.23	25.40		22.23			02691-00615					
	23.80	26.97		23.80			02691-00616					
	25.40	28.58		25.40			02691-00617					
	26.97	30.15		26.97			02691-00618					
	28.58	31.75		28.58			02691-00619					
30.15	33.32	30.15	02691-00620									

all dimensions in mm / en millimètre / alle Maße in mm / in millimetri / en milímetros

1) Flanged collars are used in applications where the hole on the collar side of the application is oversized or is slotted for alignment purposes. To determine what length of pin is required, add dimension U to the thickness of material being fastened.

Avec une bague à embase, la plage de serrage est diminuée de la valeur de la cote U.

Schließringe mit Bund werden in Anwendungen benötigt, wo das Bohrloch auf der Schließringseite übergroß oder länglich ist. Um den richtigen Bolzen zu bestimmen, addieren Sie das Maß U zu der zu verbindenden Materialstärke hinzu.

Utilizzando i collari flangiati la dimensione „U“ deve essere aggiunta allo spessore da serrare per determinare il tipo di bullone adatto.

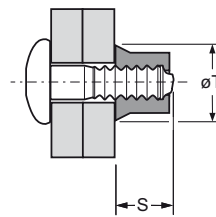
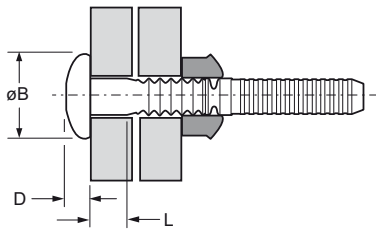

Utilizar collar con ala cuando en la aplicación el barreno está sobredimensionado o es ranurado para propósitos de alineación. Para calcular la referencia de perno es necesario añadir la cota U al espesor de la aplicación.

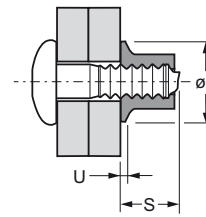

Full Collar



Flanged Collar

Ø nom.	 w. Full Collar		 L	ØB max.	D max.	Part No/ref Pin	Part No/ref Full Collar		Part No/ref Flanged Collar ¹⁾					
	min.	max.					S max.	ØT max.	S max.	ØT max.	U ¹⁾ nom.			
6.4 (1/4")	1.57	4.75	1.57	6.6	13.4	4.1	02691-00802	02605-70800	12.2	10.6	02648-70800	13.2	13.1	0.94
	3.18	6.35	3.18				02691-00803							
	4.75	7.92	4.75				02691-00804							
	6.35	9.53	6.35				02691-00805							
	7.92	11.10	7.92				02691-00806							
	9.53	12.70	9.53				02691-00807							
	11.10	14.27	11.10				02691-00808							
	12.70	15.88	12.70				02691-00809							
	14.27	17.45	14.27				02691-00810							
	15.88	19.05	15.88				02691-00811							
	17.45	20.62	17.45				02691-00812							
	19.05	22.23	19.05				02691-00813							
	20.62	23.80	20.62				02691-00814							
	22.23	25.40	22.23				02691-00815							
	23.80	26.97	23.80				02691-00816							
	26.97	30.15	26.97				02691-00818							
30.15	33.32	30.15	02691-00820											
8.0 (5/16")	3.18	9.53	3.18	8.2	16.7	5.5	02691-01004	02605-71000	15.5	13.3	N/A			
	6.35	12.70	6.35				02691-01006							
	9.53	15.88	9.53				02691-01008							
	12.70	19.05	12.70				02691-01010							
	15.88	22.23	15.88				02691-01012							
	19.05	25.40	19.05				02691-01014							
	22.23	28.58	22.23				02691-01016							
	25.40	31.75	25.40				02691-01018							
	28.58	34.93	28.58				02691-01020							
	31.75	38.10	31.75				02691-01022							
	34.93	41.28	34.93				02691-01024							
	38.10	44.45	38.10				02691-01026							
	41.28	47.63	41.28				02691-01028							
	44.45	50.80	44.45				02691-01030							
	47.63	53.98	47.63				02691-01032							

all dimensions in mm / en millimètre / alle Maße in mm / in millimetri / en milímetros

1) Flanged collars are used in applications where the hole on the collar side of the application is oversize or is slotted for alignment purposes. To determine what length of pin is required, add dimension U to the thickness of material being fastened.

Avec une bague à embase, la plage de serrage est diminuée de la valeur de la cote U.

Schließringe mit Bund werden in Anwendungen benötigt, wo das Bohrloch auf der Schließringseite übergroß oder länglich ist. Um den richtigen Bolzen zu bestimmen, addieren Sie das Maß U zu der zu verbindenden Materialstärke hinzu.

Utilizzando i collari flangiati la dimensione „U“ deve essere aggiunta allo spessore da serrare per determinare il tipo di bullone adatto.

Utilizar collar con ala cuando en la aplicación el barrenado está sobredimensionado o es ranurado para propósitos de alineación. Para calcular la referencia de perno es necesario añadir la cota U al espesor de la aplicación.

Avdelok® 2691 Series Lockbolt Fastener

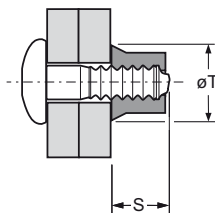
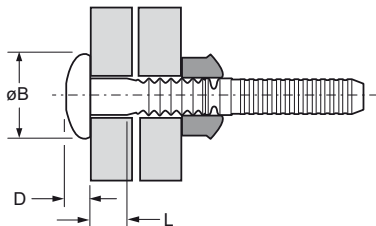

Full Collar

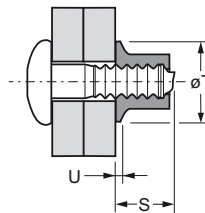

Flanged Collar

Ø nom.	w. Full Collar		L nom.	ØB max.	D max.	Part No/ref Pin	Part No/ref Full Collar		Part No/ref Flanged Collar ¹⁾			
	min.	max.					S max.	ØT max.	S max.	ØT max.	U ¹⁾ nom.	
9.6 (3/8")	3.18	9.53	3.18	20.0	6.7	02691-01204	02605-71200	18.6	15.5	N/A		
	6.35	12.70	6.35			02691-01206						
	9.53	15.88	9.53			02691-01208						
	12.70	19.05	12.70			02691-01210						
	15.88	22.23	15.88			02691-01212						
	19.05	25.40	19.05			02691-01214						
	22.23	28.58	22.23			02691-01216						
	25.40	31.75	25.40			02691-01218						
	28.58	34.93	28.58			02691-01220						
	31.75	38.10	31.75			02691-01222						
	34.93	41.28	34.93			02691-01224						
	38.10	44.45	38.10			02691-01226						
	41.28	47.63	41.28			02691-01228						
	44.45	50.80	44.45			02691-01230						
	47.63	53.98	47.63			02691-01232						

all dimensions in mm / en millimètre / alle Maße in mm / in millimetri / en milímetros



1) Flanged collars are used in applications where the hole on the collar side of the application is oversize or is slotted for alignment purposes. To determine what length of pin is required, add dimension U to the thickness of material being fastened.

Avec une bague à embase, la plage de serrage est diminuée de la valeur de la cote U.

Schließringe mit Bund werden in Anwendungen benötigt, wo das Bohrloch auf der Schließringseite übergroß oder länglich ist. Um den richtigen Bolzen zu bestimmen, addieren Sie das Maß U zu der zu verbindenden Materialstärke hinzu.

Utilizzando i collari flangiati la dimensione „U“ deve essere aggiunta allo spessore da serrare per determinare il tipo di bullone adatto.

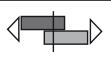
Utilizar collar con ala cuando en la aplicación el barreno está sobredimensionado o es ranurado para propósitos de alineación. Para calcular la referencia de perno es necesario añadir la cota U al espesor de la aplicación.

Ø nom.	 kN ²⁾	 kN ²⁾
4.8 (3/16")	7.79	9.26
6.4 (1/4")	14.55	17.71
8.0 (5/16")	22.24	29.80
9.6 (3/8")	31.58	37.81

2) These figures represent minimum fastener shear and tensile strength values with the use of a full or flanged collar.

Cette valeurs représentent minimum résistances au cisaillement et à la traction avec l'usage d'une bague standard ou à embase.

Diese Werte repräsentieren Minimum Scher- und Zugfestigkeiten der Verbindung unter Verwendung von Standard-Schließringen oder mit Bund.

I dati indicati in tabella sono minimi e si riferiscono a bulloni installati con collari standard o flangiati.

La figura representa los valores mínimos de resistencia a la cortadura y tracción cuando se utiliza collar estándar o con ala.



English	Français	Deutsch	Italiano	Español
Brazier head	Tête plate	Flachrundkopf	Testa tonda	Cabeza alomada
Pin: Aluminium alloy*	Tige: Alliage d'aluminium*	Bolzen: Aluminium*	Bullone: Lega di alluminio*	Vástago: Aluminio*
Polished	Poli	Poliert	Lucido	Pulido
Collar: Aluminium alloy**	Bague: Alliage d'aluminium**	Schließring: Aluminium**	Collare: Lega di alluminio**	Collar: Aluminio**
Natural	Brut	Blank	Nessuna finitura	Natural

*: AA 2024, DIN 1725, AlCuMg2, Werkstoff 3.1355 **: BS 1473 6061, AA 6061, DIN 1725 AlMg1SiCu, Werkstoff 3.3211

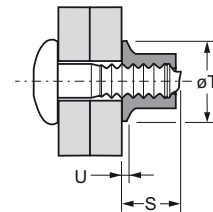
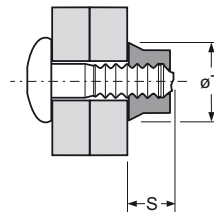
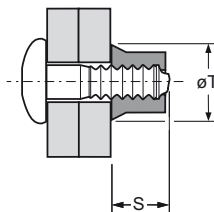
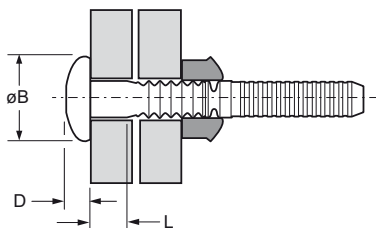

Full Collar
Schließring Standard
Bague Standard
Collare Standard
Collar Estándar

Half Collar
Schließring flach
Bague courte
Collare ribassato
Medio Collar

Flanged Collar
Schließring mit Bund
Bague à embase
Collare flangiato
Collar con Ala

ø	w. Full Collar ¹⁾		L	øB	D	Part No/ref	Part No/ref		Part No/ref				
	min.	max.					Full Collar	Half Collar ¹⁾	Flanged Collar ²⁾				
nom.			nom.	max.	max.	Pin	S max.	øT max.	S max.	øT max.	S max.	øT max.	U ²⁾ nom.
4.8 (3/16")	1.57	4.75	1.57	10.1	3.4	02801-00602	02837-00600	9.4 8.0	02838-00600	02839-00600			
	3.18	6.35	3.18										
	4.75	7.92	4.75										
	6.35	9.53	6.35										
	7.92	11.10	7.92										
	9.53	12.70	9.53										
	11.10	14.27	11.10										
	12.70	15.88	12.70										
	14.27	17.45	14.27										
	15.88	19.05	15.88										
	17.45	20.62	17.45										
	19.05	22.23	19.05										
	20.62	23.80	20.62										
	22.23	25.40	22.23										
	23.80	26.97	23.80										
	25.40	28.58	25.40										
26.97	30.15	26.97											
28.58	31.75	28.58											
30.15	33.32	30.15											

all dimensions in mm / en millimètre / alle Maße in mm / in millimetri / en milímetros

1) & 2) see page 42 / voir page 42 / siehe Seite 42 / vedi pagina 42 / ver Pág. 42

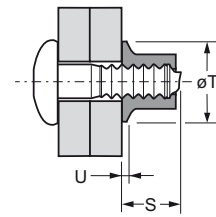
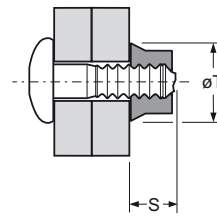
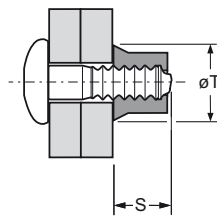
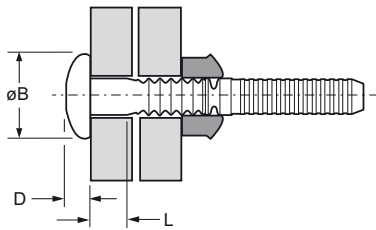

Full Collar

Half Collar

Flanged Collar

Ø nom.	w. Full Collar ¹⁾		L nom.	ØB max.	D max.	Part No/ref Pin	Part No/ref Full Collar		Part No/ref Half Collar ¹⁾		Part No/ref Flanged Collar ²⁾				
	min.	max.					S max.	ØT max.	S max.	ØT max.	S max.	ØT max.	U ²⁾ nom.		
6.4 (1/4")	1.57	4.75	6.6	1.57	13.4	4.1	02801-00802	02837-00800	12.2	10.6	02838-00800	13.2	13.1	0.94	
	3.18	6.35		3.18											02801-00803
	4.75	7.92		4.75											02801-00804
	6.35	9.53		6.35											02801-00805
	7.92	11.10		7.92											02801-00806
	9.53	12.70		9.53											02801-00807
	11.10	14.27		11.10											02801-00808
	12.70	15.88		12.70											02801-00809
	14.27	17.45		14.27											02801-00810
	15.88	19.05		15.88											02801-00811
	17.45	20.62		17.45											02801-00812
	19.05	22.23		19.05											02801-00813
	20.62	23.80		20.62											02801-00814
	22.23	25.40		22.23											02801-00815
	23.80	26.97		23.80											02801-00816
26.97	30.15	26.97	02801-00818												
30.15	33.32	30.15	02801-00820												
31.75	34.93	31.75	02801-00821												
8.0 (5/16")	3.18	9.53	8.2	3.18	16.7	5.5	02801-01004	02837-01000	15.5	13.3	02838-01000	16.8	16.3	1.22	
	6.35	12.70		6.35											02801-01006
	9.53	15.88		9.53											02801-01008
	12.70	19.05		12.70											02801-01010
	15.88	22.23		15.88											02801-01012
	19.05	25.40		19.05											02801-01014
	22.23	28.58		22.23											02801-01016
	25.40	31.75		25.40											02801-01018
	28.58	34.93		28.58											02801-01020
	31.75	38.10		31.75											02801-01022
	34.93	41.28		34.93											02801-01024
	38.10	44.45		38.10											02801-01026
	41.28	47.63		41.28											02801-01028
	44.45	50.80		44.45											02801-01030
	47.63	53.98		47.63											02801-01032
9.6 (3/8")	3.18	9.53	9.8	3.18	20.0	6.5	02801-01204	02837-01200	18.6	15.5	02838-01200	20.0	20.0	1.42	
	6.35	12.70		6.35											02801-01206
	9.53	15.88		9.53											02801-01208
	12.70	19.05		12.70											02801-01210

all dimensions in mm / en millimètre / alle Maße in mm / in millimetri / en milímetros

1) & 2) see page 42 / voir page 42 / siehe Seite 42 / vedi pagina 42 / ver Pág. 42

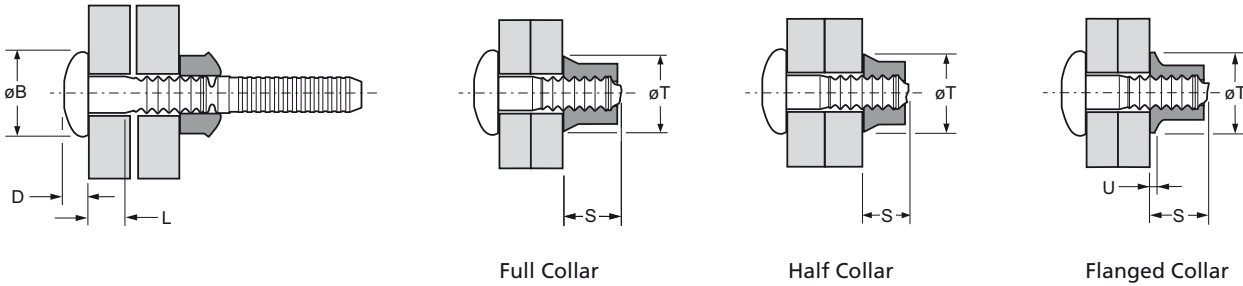

Ø nom.	w. Full Collar ¹⁾		L nom.	ØB max.	D max.	Part No/ref Pin	Part No/ref Full Collar		Part No/ref Half Collar ¹⁾		Part No/ref Flanged Collar ²⁾			
	min.	max.					S max.	ØT max.	S max.	ØT max.	S max.	ØT max.	U ²⁾ nom.	
9.6 (3/8")	15.88	22.23	15.88	20.0	6.5	02801-01212	02837-01200	18.6	15.5	02838-01200	02839-01200	20.0	20.0	1.42
	19.05	25.40	19.05			02801-01214								
	22.23	28.58	22.23			02801-01216								
	25.40	31.75	25.40			02801-01218								
	28.58	34.93	28.58			02801-01220								
	31.75	38.10	31.75			02801-01222								
	34.93	41.28	34.93			02801-01224								
	38.10	44.45	38.10			02801-01226								
	41.28	47.63	41.28			02801-01228								
	44.45	50.80	44.45			02801-01230								
	47.63	53.98	47.63			02801-01232								

all dimensions in mm / en millimètre / alle Maße in mm / in millimetri / en milímetros

1) Half collars increase the grip range to that of the next longest pin. Maximum grip increases by 1.57 mm for 4.8 mm and 6.4 mm fasteners and 3.18 mm for 8.0 mm and 9.6 mm fasteners.

Avec une bague courte, la plage de serrage maximale est équivalente à celle de l'Avdelok de longueur immédiatement supérieure. La plage de serrage augmente de 1.57 mm pour tiges de 4.8 mm et 6.4 mm, et de 3.18 mm pour tiges de 8.0 mm et 9.6 mm.

Die Verwendung von flachen Schließringen erhöht den Klemmbereich auf den des nächstlängeren Bolzens. Der maximale Klemmbereich erhöht sich um 1,6 mm für Ø 4,8 mm und Ø 6,4 mm Bolzen und 3,2 mm für Ø 8,0 mm und Ø 9,6 mm Bolzen.

Utilizzando i collari ribassati lo spessore serrabile aumenta, ed è uguale a quello massimo del bullone di misura superiore. Il massimo spessore serrabile aumenta di 1.57 mm per i bulloni da 4.8 mm e 6.4 mm e di 3.18 mm per i bulloni da 8.0 mm e 9.6 mm.

El empleo de medio collar incrementa el máx. espesor a remachar al de la siguiente toma. El máximo espesor a remachar por uso de medio collar es de 1,57 mm para diámetros de 4,8 y 6,4 mm y de 3,18 mm para diámetros de 8 y 9,6 mm.



2) Flanged collars are used in applications where the hole on the collar side of the application is oversize or is slotted for alignment purposes. To determine what length of pin is required, add dimension U to the thickness of material being fastened.

Avec une bague à embase, la plage de serrage est diminuée de la valeur de la cote U.

Schließringe mit Bund werden in Anwendungen benötigt, wo das Bohrloch auf der Schließringseite übergroß oder länglich ist. Um den richtigen Bolzen zu bestimmen, addieren Sie das Maß U zu der zu verbindenden Materialstärke hinzu.

Utilizzando i collari flangiati la dimensione „U“ deve essere aggiunta allo spessore da serrare per determinare il tipo di bullone adatto.

Utilizar collar con ala cuando en la aplicación el barreno está sobredimensionado o es ranurado para propósitos de alineación. Para calcular la referencia de perno es necesario añadir la cota U al espesor de la aplicación.

Ø nom.	 kN ³⁾	 kN ³⁾
4.8	4.67	4.72
6.4	8.34	7.92
8.0	13.02	12.68
9.6	18.69	18.68

3) These figures represent minimum fastener shear and tensile strength values with the use of a full or flanged collar. When using half collars tension is reduced to approximately 45 %.

Cette valeurs représentent minimum résistances au cisaillement et à la traction avec l'usage d'une bague standard ou à embase. Avec l'usage des bagues courtes la résistance à la traction se diminue à env. 45 %.

Diese Werte repräsentieren Minimum Scher- und Zugfestigkeiten der Verbindung unter Verwendung von Schließringen Standard oder mit Bund. Bei Verwendung von flachen Schließringen reduziert sich die Zugfestigkeit auf ca. 45 %.

I dati si riferiscono a bulloni installati con collari standard o flangiato, utilizzando collari ribassati i valori di trazione diminuiscono del 45 % circa, i valori di taglio rimangono invariati. I dati indicati in tabella sono minimi.

La figura representa los valores mínimos de resistencia a la cortadura y tracción cuando se utiliza collar estándar o con ala. Cuando se utiliza medio collar se reducen aproximadamente en un 45 %.



English	Français	Deutsch	Italiano	Español
90° Countersunk	90° Tête fraisée	90° Senkkopf	90° Testa svasata	90° Cabeza avellanada
Pin: Aluminium alloy*	Tige: Alliage d'aluminium*	Bolzen: Aluminium*	Bullone: Lega di alluminio*	Vástago: Aluminio*
Polished	Poli	Poliert	Lucido	Pulido
Collar: Aluminium alloy**	Bague: Alliage d'aluminium**	Schließring: Aluminium**	Collare: Lega di alluminio**	Collar: Aluminio**
Natural	Brut	Blank	Nessuna finitura	Natural

*: AA 2024, DIN 1725, AlCuMg2, Werkstoff 3.1355 **: BS 1473 6061, AA 6061, DIN 1725 AlMg1SiCu, Werkstoff 3.3211

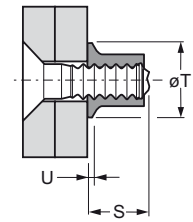
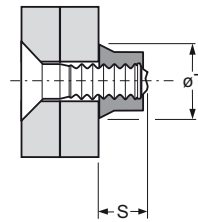
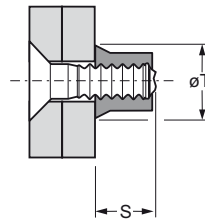
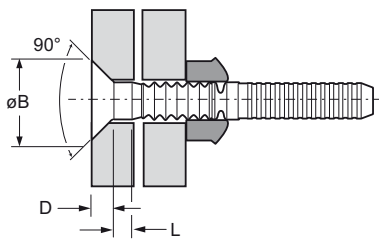

Full Collar
Schließring Standard
Bague Standard
Collare Standard
Collar Estándar

Half Collar
Schließring flach
Bague courte
Collare ribassato
Medio Collar

Flanged Collar
Schließring mit Bund
Bague à embase
Collare flangiato
Collar con Ala

ø	w. Full Collar ¹⁾		L	øB	D	Part No/ref	Part No/ref		Part No/ref		Part No/ref		
	min.	max.					Full Collar		Half Collar ¹⁾		Flanged Collar ²⁾		
nom.			nom.	max.	max.	Pin	S max.	øT max.	S max.	øT max.	S max.	øT max.	U ²⁾ nom.
4.8 (3/16")	3.18	6.35	3.18	8.9	2.2	02802-00603	02837-00600	9.4 8.0	02838-00600	7.9 8.0	02839-00600 10.2 9.9 0.76		
	4.75	7.92	4.75			02802-00604							
	6.35	9.53	6.35			02802-00605							
	7.92	11.10	7.92			02802-00606							
	9.53	12.70	9.53			02802-00607							
	11.10	14.27	11.10			02802-00608							
	12.70	15.88	12.70			02802-00609							
	14.27	17.45	14.27			02802-00610							
	15.88	19.05	15.88			02802-00611							
	17.45	20.62	17.45			02802-00612							
	19.05	22.23	19.05			02802-00613							
	20.62	23.80	20.62			02802-00614							
	22.23	25.40	22.23			02802-00615							
	23.80	26.97	23.80			02802-00616							
	25.40	28.58	25.40			02802-00617							
	26.97	30.15	26.97			02802-00618							
28.58	31.75	28.58	02802-00619										
30.15	33.32	30.15	02802-00620										

all dimensions in mm / en millimètre / alle Maße in mm / in millimetri / en milímetros

1) & 2) see page 45 / voir page 45 / siehe Seite 45 / vedi pagina 45 / ver Pág. 45

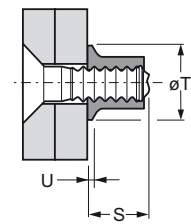
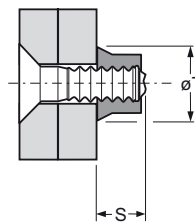
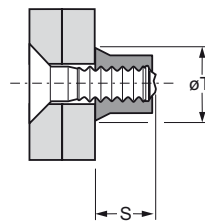
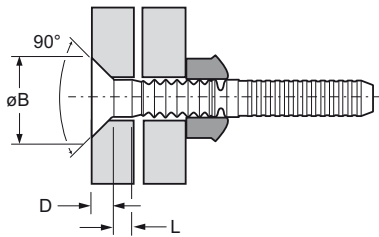

Full Collar

Half Collar

Flanged Collar

ø nom.	w. Full Collar ¹⁾		L nom.	øB max.	D max.	Part No/ref Pin	Part No/ref Full Collar		Part No/ref Half Collar ¹⁾		Part No/ref Flanged Collar ²⁾			
	min.	max.					S max.	øT max.	S max.	øT max.	S max.	øT max.	U ²⁾ nom.	
6.4 (1/4")	3.18	6.35	6.6	3.18	11.8	2.9	02802-00803	02837-00800	02838-00800	02839-00800	13.2	13.1	0.94	
	4.75	7.92		4.75										02802-00804
	6.35	9.53		6.35										02802-00805
	7.92	11.10		7.92										02802-00806
	9.53	12.70		9.53										02802-00807
	11.10	14.27		11.10										02802-00808
	12.70	15.88		12.70										02802-00809
	14.27	17.45		14.27										02802-00810
	15.88	19.05		15.88										02802-00811
	17.45	20.62		17.45										02802-00812
	19.05	22.23		19.05										02802-00813
	20.62	23.80		20.62										02802-00814
	22.23	25.40		22.23										02802-00815
	23.80	26.97		23.80										02802-00816
26.97	30.15	26.97	02802-00818											
30.15	33.32	30.15	02802-00820											
8.0 (5/16")	3.18	9.53	8.2	3.18	14.8	3.7	02802-01004	02837-01000	02838-01000	02839-01000	16.8	16.3	1.22	
	6.35	12.70		6.35										02802-01006
	9.53	15.88		9.53										02802-01008
	12.70	19.05		12.70										02802-01010
	15.88	22.23		15.88										02802-01012
	19.05	25.40		19.05										02802-01014
	22.23	28.58		22.23										02802-01016
	25.40	31.75		25.40										02802-01018
	28.58	34.93		28.58										02802-01020
	31.75	38.10		31.75										02802-01022
	34.93	41.28		34.93										02802-01024
	38.10	44.45		38.10										02802-01026
	41.28	47.63		41.28										02802-01028
	44.45	50.80		44.45										02802-01030
47.63	53.98	47.63	02802-01032											
9.6 (3/8")	6.35	12.70	9.8	6.35	17.7	4.4	02802-01206	02837-01200	02838-01200	02839-01200	20.0	20.0	1.42	
	9.53	15.88		9.53										02802-01208
	12.70	19.05		12.70										02802-01210
	15.88	22.23		15.88										02802-01212
	19.05	25.40		19.05										02802-01214
	22.23	28.58		22.23										02802-01216

all dimensions in mm / en millimètre / alle Maße in mm / in millimetri / en milímetros

1) & 2) see page 45 / voir page 45 / siehe Seite 45 / vedi pagina 45 / ver Pág. 45

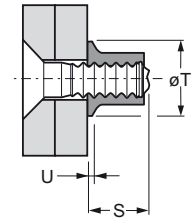
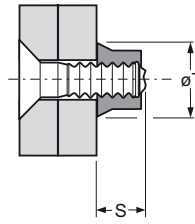
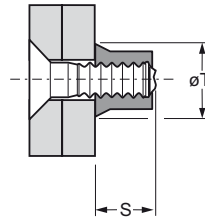
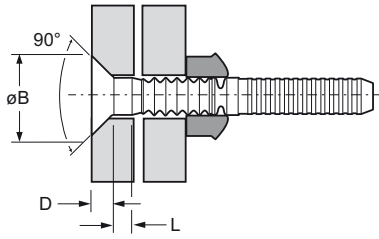

Full Collar

Half Collar

Flanged Collar

Ø nom.	w. Full Collar ¹⁾		L nom.	ØB max.	D max.	Part No/ref Pin	Part No/ref Full Collar		Part No/ref Half Collar ¹⁾		Part No/ref Flanged Collar ²⁾			
	min.	max.					S max.	ØT max.	S max.	ØT max.	S max.	ØT max.	U ²⁾ nom.	
9.6 (3/8")	25.40	31.75	9.8	25.40	17.7	4.4	02802-01218	02837-01200	18.6	15.5	02838-01200	20.0	20.0	1.42
	28.58	34.93		02802-01220										
	31.75	38.10		02802-01222										
	34.93	41.28		02802-01224										
	38.10	44.45		02802-01226										
	41.28	47.63		02802-01228										
	44.45	50.80		02802-01230										
	47.63	53.98		02802-01232										

all dimensions in mm / en millimètre / alle Maße in mm / in millimetri / en milímetros

1) Half collars increase the grip range to that of the next longest pin. Maximum grip increases by 1.57 mm for 4.8 mm and 6.4 mm fasteners and 3.18 mm for 8.0 mm and 9.6 mm fasteners.

Avec une bague courte, la plage de serrage maximale est équivalente à celle de l'Avdelok de longueur immédiatement supérieure. La plage de serrage augmente de 1.57 mm pour tiges de 4.8 mm et 6.4 mm, et de 3.18 mm pour tiges de 8.0 mm et 9.6 mm.

Die Verwendung von flachen Schließringen erhöht den Klemmbereich auf den des nächstlängeren Bolzens. Der maximale Klemmbereich erhöht sich um 1,6 mm für Ø 4,8 mm und Ø 6,4 mm Bolzen und 3,2 mm für Ø 8,0 mm und Ø 9,6 mm Bolzen.

Utilizzando i collari ribassati lo spessore serrabile aumenta, ed è uguale a quello massimo del bullone di misura superiore. Il massimo spessore serrabile aumenta di 1.57 mm per i bulloni da 4.8 mm e 6.4 mm e di 3.18 mm per i bulloni da 8.0 mm e 9.6 mm.

El empleo de medio collar incrementa el máx. espesor a remachar al de la siguiente toma. El máximo espesor a remachar por uso de medio collar es de 1,57 mm para diámetros de 4,8 y 6,4 mm y de 3,18 mm para diámetros de 8 y 9,6 mm.



2) Flanged collars are used in applications where the hole on the collar side of the application is oversized or is slotted for alignment purposes. To determine what length of pin is required, add dimension U to the thickness of material being fastened.

Avec une bague à embase, la plage de serrage est diminuée de la valeur de la cote U.

Schließringe mit Bund werden in Anwendungen benötigt, wo das Bohrloch auf der Schließringseite übergroß oder länglich ist. Um den richtigen Bolzen zu bestimmen, addieren Sie das Maß U zu der zu verbindenden Materialstärke hinzu.

Utilizzando i collari flangiati la dimensione „U“ deve essere aggiunta allo spessore da serrare per determinare il tipo di bullone adatto.

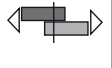
Utilizar collar con ala cuando en la aplicación el barreno está sobredimensionado o es ranurado para propósitos de alineación. Para calcular la referencia de perno es necesario añadir la cota U al espesor de la aplicación.

Ø nom.	 kN ³⁾	 kN ³⁾
4.8	4.67	4.72
6.4	8.34	7.92
8.0	13.02	12.68
9.6	18.69	18.68

3) These figures represent minimum fastener shear and tensile strength values with the use of a full or flanged collar. When using half collars tension is reduced to approximately 45 %.

Cette valeurs représentent minimum résistances au cisaillement et à la traction avec l'usage d'une bague standard ou à embase. Avec l'usage des bagues courtes la résistance à la traction se diminue à env. 45 %.

Diese Werte repräsentieren Minimum Scher- und Zugfestigkeiten der Verbindung unter Verwendung von Schließringen Standard oder mit Bund. Bei Verwendung von flachen Schließringen reduziert sich die Zugfestigkeit auf ca. 45 %.

I dati si riferiscono a bulloni installati con collari standard o flangiato, utilizzando collari ribassati i valori di trazione diminuiscono del 45 % circa, i valori di taglio rimangono invariati. I dati indicati in tabella sono minimi.

La figura representa los valores mínimos de resistencia a la cortadura y tracción cuando se utiliza collar estándar o con ala. Cuando se utiliza medio collar se reducen aproximadamente en un 45 %.



English	Français	Deutsch	Italiano	Español
Truss head	Tête large	Flachrundkopf groß	Testa larga	Cabeza alomada de perfil bajo
Pin: Aluminium alloy*	Tige: Alliage d'aluminium*	Bolzen: Aluminium*	Bullone: Lega di alluminio*	Vástago: Aluminio*
Polished	Poli	Poliert	Lucido	Pulido
Collar: Aluminium alloy**	Bague: Alliage d'aluminium**	Schließring: Aluminium**	Collare: Lega di alluminio**	Collar: Aluminio**
Natural	Brut	Blank	Nessuna finitura	Natural

*: AA 2024, DIN 1725, AlCuMg2, Werkstoff 3.1355 **: BS 1473 6061, AA 6061, DIN 1725 AlMg1SiCu, Werkstoff 3.3211

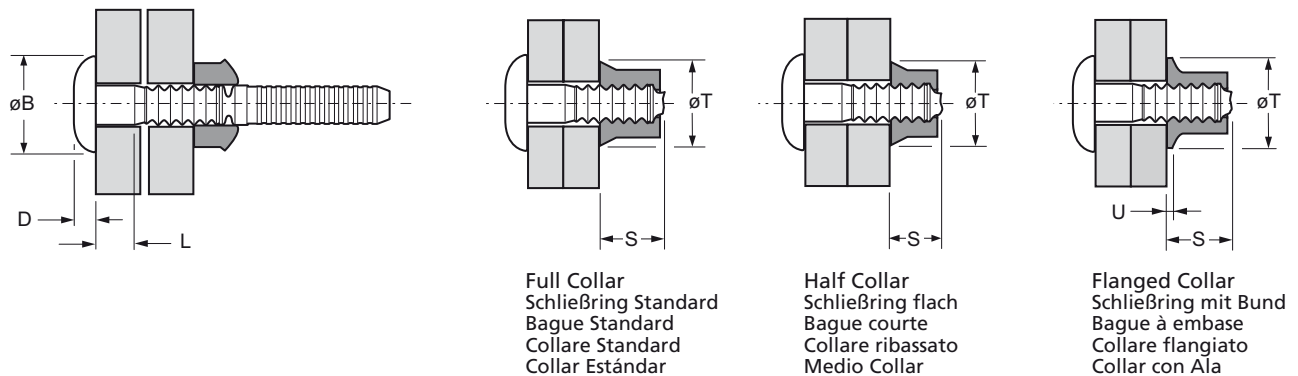

Ø	w. Full Collar ¹⁾		L	ØB	D	Part No/ref	Part No/ref		Part No/ref				
	min.	max.					Full Collar		Half Collar ¹⁾		Flanged Collar ²⁾		
nom.			nom.	max.	nom.	Pin	S max.	ØT max.	S max.	ØT max.	S max.	ØT max.	U ²⁾ nom.
4.8 (3/16")	1.57	4.75	1.57	12.0	2.2	02803-00602	02837-00600	9.4	8.0	02838-00600	10.2	9.9	0.76
	3.18	6.35	3.18			02803-00603							
	4.75	7.92	4.75			02803-00604							
	6.35	9.53	6.35			02803-00605							
	7.92	11.10	7.92			02803-00606							
	9.53	12.70	9.53			02803-00607							
	11.10	14.27	11.10			02803-00608							
	12.70	15.88	12.70			02803-00609							
	14.27	17.45	14.27			02803-00610							
	15.88	19.05	15.88			02803-00611							
	17.45	20.62	17.45			02803-00612							
	19.05	22.23	19.05			02803-00613							
	20.62	23.80	20.62			02803-00614							
	22.23	25.40	22.23			02803-00615							
	23.80	26.97	23.80			02803-00616							
	25.40	28.58	25.40			02803-00617							
	26.97	30.15	26.97			02803-00618							
	28.58	31.75	28.58			02803-00619							
30.15	33.32	30.15	02803-00620										

all dimensions in mm / en millimètre / alle Maße in mm / in millimetri / en milímetros

1) & 2) see page 48 / voir page 48 / siehe Seite 48 / vedi pagina 48 / ver Pág. 48

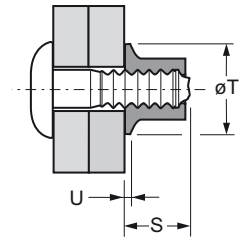
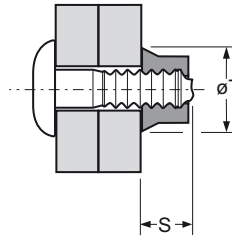
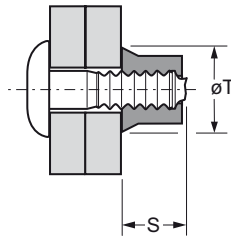
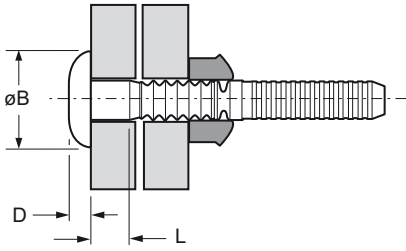

Full Collar

Half Collar

Flanged Collar

ø nom.	w. Full Collar ¹⁾		L nom.	øB max.	D nom.	Part No/ref Pin	Part No/ref Full Collar		Part No/ref Half Collar ¹⁾		Part No/ref Flanged Collar ²⁾				
	min.	max.					S max.	øT max.	S max.	øT max.	S max.	øT max.	U ²⁾ nom.		
6.4 (1/4")	1.57	4.75	6.6	1.57	15.1	2.8	02803-00802	02837-00800	12.2	10.6	02838-00800	13.2	13.1	0.94	
	3.18	6.35		3.18											02803-00803
	4.75	7.92		4.75											02803-00804
	6.35	9.53		6.35											02803-00805
	7.92	11.10		7.92											02803-00806
	9.53	12.70		9.53											02803-00807
	11.10	14.27		11.10											02803-00808
	12.70	15.88		12.70											02803-00809
	14.27	17.45		14.27											02803-00810
	15.88	19.05		15.88											02803-00811
	17.45	20.62		17.45											02803-00812
	19.05	22.23		19.05											02803-00813
	20.62	23.80		20.62											02803-00814
	22.23	25.40		22.23											02803-00815
	23.80	26.97		23.80											02803-00816
26.97	30.15	26.97	02803-00818												
30.15	33.32	30.15	02803-00820												
31.75	34.93	31.75	02803-00821												
8.0 (5/16")	3.18	9.53	8.2	3.18	19.9	3.6	02803-01004	02837-01000	15.5	13.3	02838-01000	16.8	16.3	1.22	
	6.35	12.70		6.35											02803-01006
	9.53	15.88		9.53											02803-01008
	12.70	19.05		12.70											02803-01010
	15.88	22.23		15.88											02803-01012
	19.05	25.40		19.05											02803-01014
	22.23	28.58		22.23											02803-01016
	25.40	31.75		25.40											02803-01018
	28.58	34.93		28.58											02803-01020
	31.75	38.10		31.75											02803-01022
	34.93	41.28		34.93											02803-01024
	38.10	44.45		38.10											02803-01026
	41.28	47.63		41.28											02803-01028
	44.45	50.80		44.45											02803-01030
	47.63	53.98		47.63											02803-01032
9.6 (3/8")	3.18	9.53	9.8	3.18	23.5	4.1	02803-01204	02837-01200	18.6	15.5	02838-01200	20.0	20.0	1.42	
	6.35	12.70		6.35											02803-01206
	9.53	15.88		9.53											02803-01208
	12.70	19.05		12.70											02803-01210

all dimensions in mm / en millimètre / alle Maße in mm / in millimetri / en milímetros

1) & 2) see page 48 / voir page 48 / siehe Seite 48 / vedi pagina 48 / ver Pág. 48

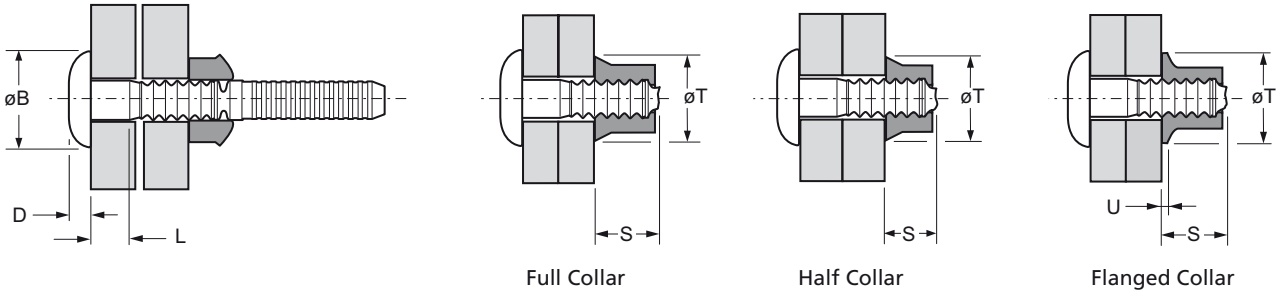

ø	w. Full Collar ¹⁾		L	øB	D	Part No/ref	Part No/ref		Part No/ref				
	min.	max.					Full Collar	Half Collar ¹⁾	Flanged Collar ²⁾				
nom.			nom.	max.	nom.	Pin	S max.	øT max.	S max.	øT max.	S max.	øT max.	U ²⁾ nom.
9.6 (3/8")	15.88	22.23	15.88	23.5	4.1	02803-01212	02837-01200	18.6	15.5	02838-01200	20.0	20.0	1.42
	19.05	25.40	19.05			02803-01214							
	22.23	28.58	22.23			02803-01216							
	25.40	31.75	25.40			02803-01218							
	28.58	34.93	28.58			02803-01220							
	31.75	38.10	31.75			02803-01222							
	34.93	41.28	34.93			02803-01224							
	38.10	44.45	38.10			02803-01226							
	41.28	47.63	41.28			02803-01228							
	44.45	50.80	44.45			02803-01230							
	47.63	53.98	47.63			02803-01232							

all dimensions in mm / en millimètre / alle Maße in mm / in millimetri / en milímetros

1) Half collars increase the grip range to that of the next longest pin. Maximum grip increases by 1.57 mm for 4.8 mm and 6.4 mm fasteners and 3.18 mm for 8.0 mm and 9.6 mm fasteners.

Avec une bague courte, la plage de serrage maximale est équivalente à celle de l'Avdelok de longueur immédiatement supérieure. La plage de serrage augmente de 1.57 mm pour tiges de 4.8 mm et 6.4 mm, et de 3.18 mm pour tiges de 8.0 mm et 9.6 mm.

Die Verwendung von flachen Schließringen erhöht den Klemmbereich auf den des nächstlängeren Bolzens. Der maximale Klemmbereich erhöht sich um 1,6 mm für ø 4,8 mm und ø 6,4 mm Bolzen und 3,2 mm für ø 8,0 mm und ø 9,6 mm Bolzen.

Utilizzando i collari ribassati lo spessore serrabile aumenta, ed è uguale a quello massimo del bullone di misura superiore. Il massimo spessore serrabile aumenta di 1.57 mm per i bulloni da 4.8 mm e 6.4 mm e di 3.18 mm per i bulloni da 8.0 mm e 9.6 mm.

El empleo de medio collar incrementa el máx. espesor a remachar al de la siguiente toma. El máximo espesor a remachar por uso de medio collar es de 1,57 mm para diámetros de 4,8 y 6,4 mm y de 3,18 mm para diámetros de 8 y 9,6 mm.



2) Flanged collars are used in applications where the hole on the collar side of the application is oversize or is slotted for alignment purposes. To determine what length of pin is required, add dimension U to the thickness of material being fastened.

Avec une bague à embase, la plage de serrage est diminuée de la valeur de la cote U.

Schließringe mit Bund werden in Anwendungen benötigt, wo das Bohrloch auf der Schließringseite übergroß oder länglich ist. Um den richtigen Bolzen zu bestimmen, addieren Sie das Maß U zu der zu verbindenden Materialstärke hinzu.

Utilizzando i collari flangiati la dimensione „U“ deve essere aggiunta allo spessore da serrare per determinare il tipo di bullone adatto.

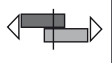
Utilizar collar con ala cuando en la aplicación el barreno está sobredimensionado o es ranurado para propósitos de alineación. Para calcular la referencia de perno es necesario añadir la cota U al espesor de la aplicación.

ø		
nom.	kN ³⁾	kN ³⁾
4.8	4.67	4.72
6.4	8.34	7.92
8.0	13.02	12.68
9.6	18.69	18.68

3) These figures represent minimum fastener shear and tensile strength values with the use of a full or flanged collar. When using half collars tension is reduced to approximately 45 %.

Cette valeurs représentent minimum résistances au cisaillement et à la traction avec l'usage d'une bague standard ou à embase. Avec l'usage des bagues courtes la résistance à la traction se diminue à env. 45 %.

Diese Werte repräsentieren Minimum Scher- und Zugfestigkeiten der Verbindung unter Verwendung von Schließringen Standard oder mit Bund. Bei Verwendung von flachen Schließringen reduziert sich die Zugfestigkeit auf ca. 45 %.

I dati si riferiscono a bulloni installati con collari standard o flangiato, utilizzando collari ribassati i valori di trazione diminuiscono del 45 % circa, i valori di taglio rimangono invariati. I dati indicati in tabella sono minimi.

La figura representa los valores mínimos de resistencia a la cortadura y tracción cuando se utiliza collar estándar o con ala. Cuando se utiliza medio collar se reducen aproximadamente en un 45 %.



English	Français	Deutsch	Italiano	Español
Large head	Tête large	Rundkopf extragroß	Testa larga	Cabeza ancha
Pin: Aluminium alloy*	Tige: Alliage d'aluminium*	Bolzen: Aluminium*	Bullone: Lega di alluminio*	Vástago: Aluminio*
Polished	Poli	Poliert	Lucido	Pulido
Collar: Aluminium alloy**	Bague: Alliage d'aluminium**	Schließring: Aluminium**	Collare: Lega di alluminio**	Collar: Aluminio**
Natural	Brut	Blank	Nessuna finitura	Natural

*: AA 2024, DIN 1725, AlCuMg2, Werkstoff 3.1355 **: BS 1473 6061, AA 6061, DIN 1725 AlMg1SiCu, Werkstoff 3.3211

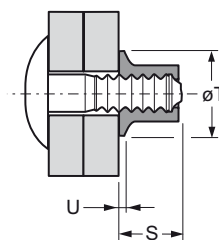
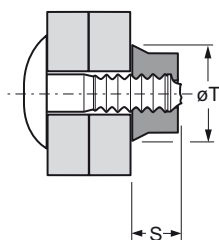
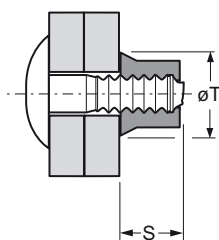
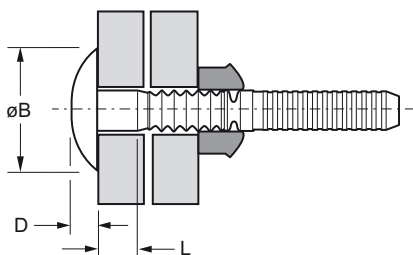

Full Collar
Schließring Standard
Bague Standard
Collare Standard
Collar Estándar

Half Collar
Schließring flach
Bague courte
Collare ribassato
Medio Collar

Flanged Collar
Schließring mit Bund
Bague à embase
Collare flangiato
Collar con Ala

Ø	w. Full Collar ¹⁾		L	ØB	D	Part No/ref	Part No/ref		Part No/ref		Part No/ref		
	min.	max.					Full Collar	Half Collar ¹⁾	Flanged Collar ²⁾				
nom.			nom.	max.	nom.	Pin	S max.	ØT max.	S max.	ØT max.	S max.	ØT max.	U ²⁾ nom.
9.6 (3/8")	9.53	15.88	9.8	9.53	32.2	5.0	02804-01208	02837-01200	18.6	15.5	02838-01200	15.5	02839-01200
	12.70	19.05		12.70			02804-01210						
	15.88	22.23		15.88			02804-01212						
	19.05	25.40		19.05			02804-01214						
	22.23	28.58		22.23			02804-01216						
	25.40	31.75		25.40			02804-01218						
	28.58	34.93		28.58			02804-01220						
	31.75	38.10		31.75			02804-01222						
	34.93	41.28		34.93			02804-01224						
	38.10	44.45		38.10			02804-01226						
	41.28	47.63		41.28			02804-01228						
	44.45	50.80		44.45			02804-01230						
	47.63	53.98		47.63			02804-01232						

all dimensions in mm / en millimètre / alle Maße in mm / in millimetri / en milímetros

1) & 2) see next page / voir la page suivant / siehe nächste Seite / vedi pagina successiva / ver la página siguiente

1) Half collars increase the grip range to that of the next longest pin. Maximum grip increases by 1.57 mm for 4.8 mm and 6.4 mm fasteners and 3.18 mm for 8.0 mm and 9.6 mm fasteners.

Avec une bague courte, la plage de serrage maximale est équivalente à celle de l'Avdelok de longueur immédiatement supérieure. La plage de serrage augmente de 1.57 mm pour tiges de 4.8 mm et 6.4 mm, et de 3.18 mm pour tiges de 8.0 mm et 9.6 mm.

Die Verwendung von flachen Schließringen erhöht den Klemmbereich auf den des nächstlängeren Bolzens. Der maximale Klemmbereich erhöht sich um 1,6 mm für ø 4,8 mm und ø 6,4 mm Bolzen und 3,2 mm für ø 8,0 mm und ø 9,6 mm Bolzen.

Utilizzando i collari ribassati lo spessore serrabile aumenta, ed è uguale a quello massimo del bullone di misura superiore. Il massimo spessore serrabile aumenta di 1.57 mm per i bulloni da 4.8 mm e 6.4 mm e di 3.18 mm per i bulloni da 8.0 mm e 9.6 mm.

El empleo de medio collar incrementa el máx. espesor a remachar al de la siguiente toma. El máximo espesor a remachar por uso de medio collar es de 1,57 mm para diámetros de 4,8 y 6,4 mm y de 3,18 mm para diámetros de 8 y 9,6 mm.



2) Flanged collars are used in applications where the hole on the collar side of the application is oversized or is slotted for alignment purposes. To determine what length of pin is required, add dimension U to the thickness of material being fastened.

Avec une bague à embase, la plage de serrage est diminuée de la valeur de la cote U.

Schließringe mit Bund werden in Anwendungen benötigt, wo das Bohrloch auf der Schließringseite übergroß oder länglich ist. Um den richtigen Bolzen zu bestimmen, addieren Sie das Maß U zu der zu verbindenden Materialstärke hinzu.

Utilizzando i collari flangiati la dimensione „U“ deve essere aggiunta allo spessore da serrare per determinare il tipo di bullone adatto.

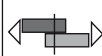
Utilizar collar con ala cuando en la aplicación el barreno está sobredimensionado o es ranurado para propósitos de alineación. Para calcular la referencia de perno es necesario añadir la cota U al espesor de la aplicación.

ø		
nom.	kN ³⁾	kN ³⁾
9.6	18.69	18.68

3) These figures represent minimum fastener shear and tensile strength values with the use of a full or flanged collar. When using half collars tension is reduced to approximately 45 %.

Cette valeurs représentent minimum résistances au cisaillement et à la traction avec l'usage d'une bague standard ou à embase. Avec l'usage des bagues courtes la résistance à la traction se diminue à env. 45 %.

Diese Werte repräsentieren Minimum Scher- und Zugfestigkeiten der Verbindung unter Verwendung von Schließringen Standard oder mit Bund. Bei Verwendung von flachen Schließringen reduziert sich die Zugfestigkeit auf ca. 45 %.

I dati si riferiscono a bulloni installati con collari standard o flangiato, utilizzando collari ribassati i valori di trazione diminuiscono del 45 % circa, i valori di taglio rimangono invariati. I dati indicati in tabella sono minimi.

La figura representa los valores mínimos de resistencia a la cortadura y tracción cuando se utiliza collar estándar o con ala. Cuando se utiliza medio collar se reducen aproximadamente en un 45 %.





English	Français	Deutsch	Italiano	Español
Round head	Tête plate	Rundkopf	Testa tonda	Cabeza alomada
Pin: Carbon steel Black self-colour	Tige: Acier Noir	Bolzen: Stahl Schwarz	Bullone: Acciaio Negro	Vástago: Acero Pavonado
Collar: Low carbon steel Zinc plated, 10 µm	Bague: Acier Zingué, 10 µm	Schließring: Stahl Verzinkt, 10 µm	Collare: Acciaio Zincato, 10 µm	Collar: Acero Zincado, 10 µm

Options:

2852 series: 10 µm zinc plated, clear trivalent passivated / 10 µm zingué, passivation claire trivalente / 10 µm verzinkt, klar chromatiert, Cr6-frei / 10 µm zincato, passivazione chiara trivalente / 10 µm zincado, pasivado claro trivalente

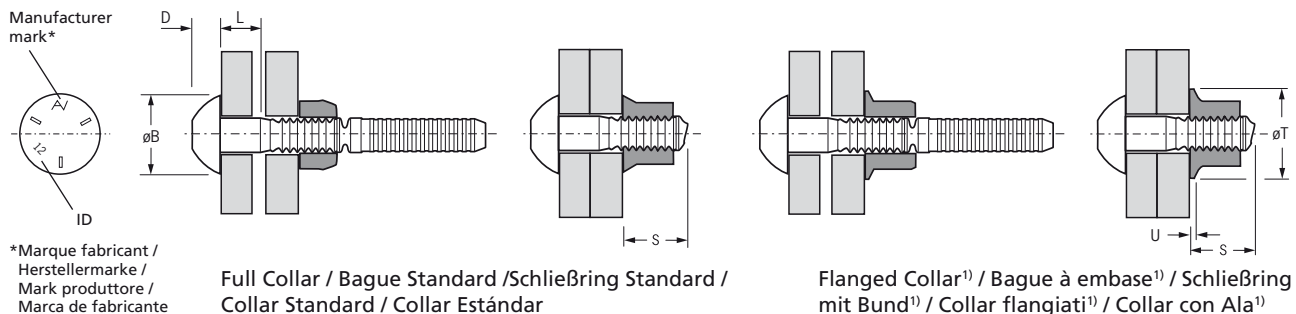
2853 series: 15 µm zinc plated, clear trivalent passivated / 15 µm zingué, passivation claire trivalente / 15 µm verzinkt, klar chromatiert, Cr6-frei / 15 µm zincato, passivazione chiara trivalente / 15 µm zincado, pasivado claro trivalente



ø nom.					L nom.	øB max.	D max.	Part No/ref					
	ID	min.	max.					Pin	Full Collar S max.	Flanged Collar ¹⁾ S max. øT max. U ¹⁾			
12.7 (1/2")	4	6.35	12.70	13.5	4.60	23.9	8.4	02851-01604	02662-01600	02615-01600 29.7 26.2 3.18			
	8	12.70	19.05		10.95								02851-01608
	12	19.05	25.40		17.30								02851-01612
	16	25.40	31.75		23.65								02851-01616
	20	31.75	38.10		30.00								02851-01620
	24	38.10	44.45		36.35								02851-01624
	28	44.45	50.80		42.70								02851-01628
	32	50.80	57.15		49.05								02851-01632
	36	57.15	63.50		55.40								02851-01636
	40	63.50	69.85		61.75								02851-01640
	44	69.85	76.20		68.10								02851-01644
	48	76.20	82.55		74.45								02851-01648
	52	82.55	88.90		80.80								02851-01652
	56	88.90	95.25		87.15								02851-01656
	60	95.25	101.60		93.50								02851-01660
	64	101.60	107.95		99.85								02851-01664
68	107.95	114.30	106.20	02851-01668									
72	114.30	120.65	112.55	02851-01672									
76	120.65	127.00	118.90	02851-01676									
80	127.00	133.35	125.25	02851-01680									

all dimensions in mm / en millimètre / alle Maße in mm / in millimetri / en milímetros

1) Flanged collars are used in applications where the hole on the collar side of the application is oversize or is slotted for alignment purposes. To determine what length of pin is required, add dimension U to the thickness of material being fastened.



Avec une bague à embase, la plage de serrage est diminuée de la valeur de la cote U.

Schließringe mit Bund werden in Anwendungen benötigt, wo das Bohrloch auf der Schließringseite übergroß oder länglich ist. Um den richtigen Bolzen zu bestimmen, addieren Sie das Maß U zu der zu verbindenden Materialstärke hinzu.

Utilizzando i collari flangiati la dimensione „U“ deve essere aggiunta allo spessore da serrare per determinare il tipo di bullone adatto.

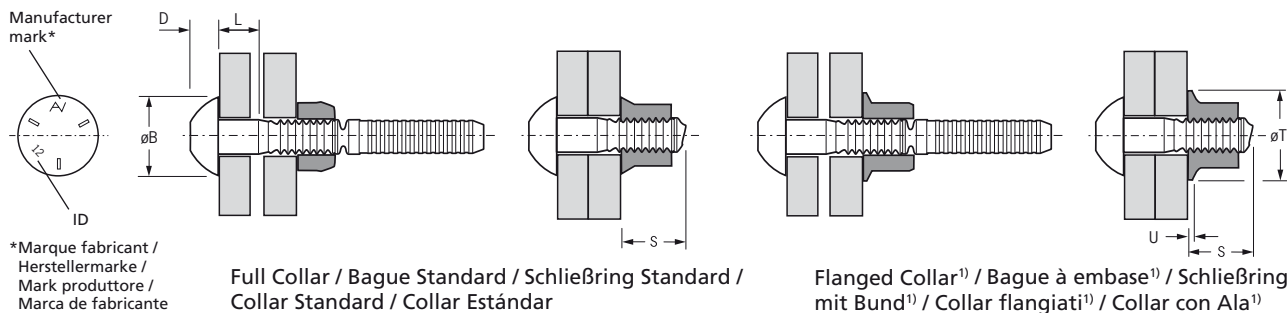
Utilizar collar con ala cuando en la aplicación el barrenado está sobredimensionado o es ranurado para propósitos de alineación. Para calcular la referencia de perno es necesario añadir la cota U al espesor de la aplicación.



ø nom.					L nom.	øB max.	D max.	Part No/ref				
	ID	min.	max.					Pin	Full Collar S max.	Flanged Collar¹) S max. øT max. U¹)		
15.9 (5/8")	4	6.35	12.70	16.7	4.60	30.2	10.6	02851-02004	02662-02000 32.6	02615-02000 36.6 32.6 3.96		
	8	12.70	19.05		10.95			02851-02008				
	12	19.05	25.40		17.30			02851-02012				
	16	25.40	31.75		23.65			02851-02016				
	20	31.75	38.10		30.00			02851-02020				
	24	38.10	44.45		36.35			02851-02024				
	28	44.45	50.80		42.70			02851-02028				
	32	50.80	57.15		49.05			02851-02032				
	36	57.15	63.50		55.40			02851-02036				
	40	63.50	69.85		61.75			02851-02040				
	44	69.85	76.20		68.10			02851-02044				
	48	76.20	82.55		74.45			02851-02048				
	52	82.55	88.90		80.80			02851-02052				
	56	88.90	95.25		87.15			02851-02056				
	60	95.25	101.60		93.50			02851-02060				
	64	101.60	107.95		99.85			02851-02064				
68	107.95	114.30	106.20	02851-02068								
72	114.30	120.65	112.55	02851-02072								
76	120.65	127.00	118.90	02851-02076								
19.1 (3/4")	4	6.35	12.70	19.9	4.60	36.6	12.7	02851-02404	02662-02400 35.0	02615-02400 39.8 38.9 4.78		
	8	12.70	19.05		10.95			02851-02408				
	12	19.05	25.40		17.30			02851-02412				
	16	25.40	31.75		23.65			02851-02416				
	20	31.75	38.10		30.00			02851-02420				
	24	38.10	44.45		36.35			02851-02424				
	28	44.45	50.80		42.70			02851-02428				
	32	50.80	57.15		49.05			02851-02432				
	36	57.15	63.50		55.40			02851-02436				
	40	63.50	69.85		61.75			02851-02440				
	44	69.85	76.20		68.10			02851-02444				
	48	76.20	82.55		74.45			02851-02448				
	52	82.55	88.90		80.80			02851-02452				
	56	88.90	95.25		87.15			02851-02456				
	60	95.25	101.60		93.50			02851-02460				
	64	101.60	107.95		99.85			02851-02464				
68	107.95	114.30	106.20	02851-02468								
72	114.30	120.65	112.55	02851-02472								
76	120.65	127.00	118.90	02851-02476								

all dimensions in mm / en millimètre / alle Maße in mm / in millimetri / en milímetros

1) Flanged collars are used in applications where the hole on the collar side of the application is oversize or is slotted for alignment purposes. To determine what length of pin is required, add dimension U to the thickness of material being fastened.



Avec une bague à embase, la plage de serrage est diminuée de la valeur de la cote U.

Schließringe mit Bund werden in Anwendungen benötigt, wo das Bohrloch auf der Schließringseite übergroß oder länglich ist. Um den richtigen Bolzen zu bestimmen, addieren Sie das Maß U zu der zu verbindenden Materialstärke hinzu.

Utilizzando i collari flangiati la dimensione „U“ deve essere aggiunta allo spessore da serrare per determinare il tipo di bullone adatto.

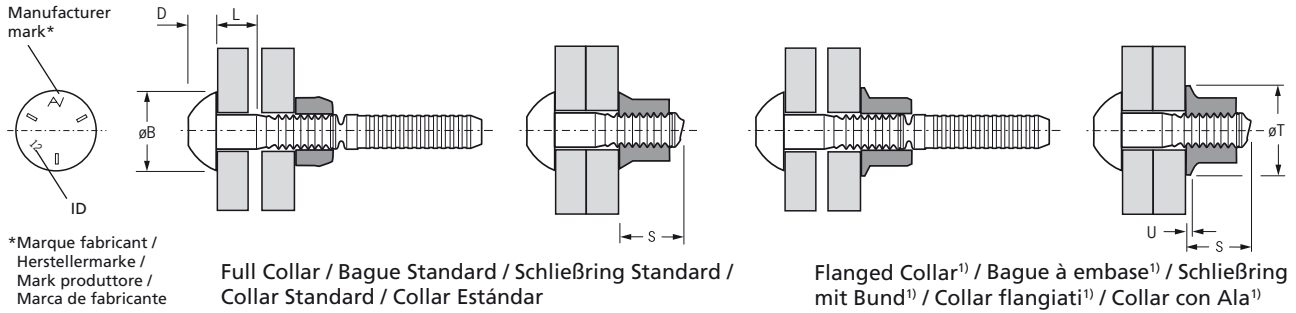
Utilizar collar con ala cuando en la aplicación el barreno está sobredimensionado o es ranurado para propósitos de alineación. Para calcular la referencia de perno es necesario añadir la cota U al espesor de la aplicación.



ø					L	øB	D	Part No/ref				
	nom.	ID	min.					max.	nom.	max.	max.	Pin
22.2 (7/8")	8	12.70	19.05	23.01	10.95	42.1	14.7	02851-02808	02662-02800	02615-02800 44.7 41.3 5.54		
	12	19.05	25.40		17.30			02851-02812				
	16	25.40	31.75		23.65			02851-02816				
	20	31.75	38.10		30.00			02851-02820				
	24	38.10	44.45		36.35			02851-02824				
	28	44.45	50.80		42.70			02851-02828				
	32	50.80	57.15		49.05			02851-02832				
	36	57.15	63.50		55.40			02851-02836				
	40	63.50	69.85		61.75			02851-02840				
	44	69.85	76.20		68.10			02851-02844				
	48	76.20	82.55		74.45			02851-02848				
	52	82.55	88.90		80.80			02851-02852				
	56	88.90	95.25		87.15			02851-02856				
	60	95.25	101.60		93.50			02851-02860				
	64	101.60	107.95		99.85			02851-02864				
	68	107.95	114.30		106.20			02851-02868				
72	114.30	120.65	112.55	02851-02872								
25.4 (1")	8	12.70	19.05	26.18	10.95	48.5	16.3	02851-03208	02662-03200	02615-03200 49.6 48.5 6.35		
	12	19.05	25.40		17.30			02851-03212				
	16	25.40	31.75		23.65			02851-03216				
	20	31.75	38.10		30.00			02851-03220				
	24	38.10	44.45		36.35			02851-03224				
	28	44.45	50.80		42.70			02851-03228				
	32	50.80	57.15		49.05			02851-03232				
	36	57.15	63.50		55.40			02851-03236				
	40	63.50	69.85		61.75			02851-03240				
	44	69.85	76.20		68.10			02851-03244				
	48	76.20	82.55		74.45			02851-03248				
	52	82.55	88.90		80.80			02851-03252				
	56	88.90	95.25		87.15			02851-03256				
	60	95.25	101.60		93.50			02851-03260				
	64	101.60	107.95		99.85			02851-03264				
	68	107.95	114.30		106.20			02851-03268				
72	114.30	120.65	112.55	02851-03272								
76	120.65	127.00	118.90	02851-03276								
80	127.00	133.35	125.25	02851-03280								
84	133.35	139.70	131.60	02851-03284								
88	139.70	146.05	137.95	02851-03288								
92	146.05	152.40	144.30	02851-03292								

all dimensions in mm / en millimètre / alle Maße in mm / in millimetri / en milímetros

1) Flanged collars are used in applications where the hole on the collar side of the application is oversize or is slotted for alignment purposes. To determine what length of pin is required, add dimension U to the thickness of material being fastened.



Avec une bague à embase, la plage de serrage est diminuée de la valeur de la cote U.

Schließringe mit Bund werden in Anwendungen benötigt, wo das Bohrloch auf der Schließringseite übergroß oder länglich ist. Um den richtigen Bolzen zu bestimmen, addieren Sie das Maß U zu der zu verbindenden Materialstärke hinzu.

Utilizzando i collari flangiati la dimensione „U” deve essere aggiunta allo spessore da serrare per determinare il tipo di bullone adatto.

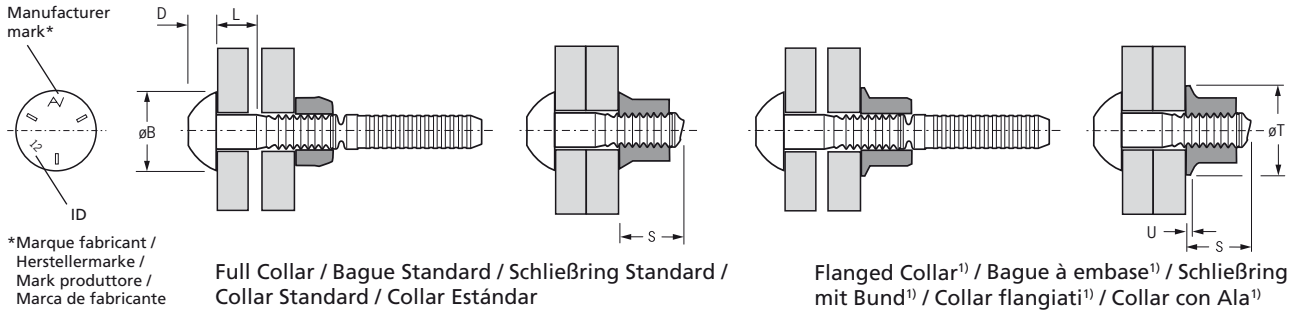
Utilizar collar con ala cuando en la aplicación el barreno está sobredimensionado o es ranurado para propósitos de alineación. Para calcular la referencia de perno es necesario añadir la cota U al espesor de la aplicación.



ø nom.					L nom.	øB max.	D max.	Part No/ref			
	ID	min.	max.					Pin	Full Collar S max.	S max.	øT max.
28.6 (1-1/8")	8	12.70	19.05	29.36	12.70	54.1	17.7	02851-03608	02662-03600 48.1	02615-03600 55.0 54.9 6.85	
	12	19.05	25.40		19.05			02851-03612			
	16	25.40	31.75		25.40			02851-03616			
	20	31.75	38.10		31.75			02851-03620			
	24	38.10	44.45		38.10			02851-03624			
	28	44.45	50.80		44.45			02851-03628			
	32	50.80	57.15		50.80			02851-03632			
	36	57.15	63.50		57.15			02851-03636			
	40	63.50	69.85		63.50			02851-03640			
	44	69.85	76.20		69.85			02851-03644			
	48	76.20	82.55		76.20			02851-03648			
	52	82.55	88.90		82.55			02851-03652			
	56	88.90	95.25		88.90			02851-03656			
	60	95.25	101.60		95.25			02851-03660			
	64	101.60	107.95		101.60			02851-03664			
	68	107.95	114.30		107.95			02851-03668			
	72	114.30	120.65		114.30			02851-03672			
	76	120.65	127.00		120.65			02851-03676			
80	127.00	133.35	127.00	02851-03680							
84	133.35	139.70	133.35	02851-03684							
88	139.70	146.05	139.70	02851-03688							
92	146.05	152.40	146.05	02851-03692							

all dimensions in mm / en millimètre / alle Maße in mm / in millimetri / en milímetros



1) Flanged collars are used in applications where the hole on the collar side of the application is oversize or is slotted for alignment purposes. To determine what length of pin is required, add dimension U to the thickness of material being fastened.

Avec une bague à embase, la plage de serrage est diminuée de la valeur de la cote U.

Schließringe mit Bund werden in Anwendungen benötigt, wo das Bohrloch auf der Schließringseite übergroß oder länglich ist. Um den richtigen Bolzen zu bestimmen, addieren Sie das Maß U zu der zu verbindenden Materialstärke hinzu.

Utilizzando i collari flangiati la dimensione „U“ deve essere aggiunta allo spessore da serrare per determinare il tipo di bullone adatto.

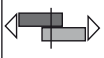
Utilizar collar con ala cuando en la aplicación el barreno está sobredimensionado o es ranurado para propósitos de alineación. Para calcular la referencia de perno es necesario añadir la cota U al espesor de la aplicación.

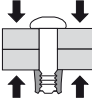
ø nom.			
	kN min.	kN min.	kN min.
12.7	64.0	75.8	53.6
15.9	100.0	120.5	85.4
19.1	144.4	178.3	126.3
22.2	193.0	246.6	174.6
25.4	251.3	323.3	229.1
28.6	309.1	368.9	259.0

Installed Avdelok XT fasteners provide a minimum shear, tensile and pre-load strength, which is equivalent to or exceeds ISO 898-1 property class 8.8 or ASTM A-325 standards. Made to British Standard B7805: Part 2:1997, the Avdelok XT fastener can be the perfect alternative to conventional property class 8.8 threaded fasteners, providing a permanent, high tensile friction grip joint but without the risk of loosening.

Une fois posées les fixations Avdelok XT proposent des performances de résistance au cisaillement et à l'arrachement et une pré-tension qui sont équivalentes ou meilleures que les propriétés d'une ISO 898-1 classe 8.8 ou de la norme ASTM A-325. Fabriquée selon la norme Anglaise B7805: Part 2:1997, la fixation Avdelok XT peut être une parfaite alternative aux boulons traditionnels de classe 8.8 et offre un assemblage permanent, haute résistance sans risque de desserrage.

Verarbeitete Avdelok XT Schließringbolzen bieten Mindestwerte für Scher- und Zugbruchlast sowie Vorspannkraft, die der ISO 898-1 Festigkeitsklasse 8.8 oder ASTM A-325 Standards entsprechen oder übertreffen. Avdelok XT werden nach British Standard B7805: Part 2:1997 hergestellt. Sie können die perfekte Alternative zu herkömmlichen 8.8 Gewindeprodukten sein und bieten eine dauerhafte, hochfest vorgespannte Verbindung ohne Risiko des ungewollten LöSENS.

I bulloni a strappo Avdelok XT, una volta installati sono paragonabili o superiori alle ISO 898-1 classi di resistenza 8.8 o ASTM A-325. Costruiti secondo le norme Britanniche B7805: Parte 2:1997, i bulloni a strappo Avdelok XT possono essere perfettamente alternativi al grado di resistenza 8.8. dei bulloni tradizionali, garantendo però un sicuro e permanente serraggio senza rischi di manomissione.

Los remaches Avdelok XT proporcionan una resistencia a cortadura y a tracción y proporcionan una fuerza de apriete, equivalentes o superiores a la tornillería de ISO 898-1 clase 8.8 o ASTM A-325. Fabricados bajo la norma British Standard B7805, parte 2:1997, los remaches Avdelok XT pueden ser una alternativa perfecta a la tornillería tradicional de clase 8.8, proporcionando una alta fricción permanente entre las piezas a unir sin el riesgo de aflojado que tienen las uniones atornilladas.



English	Français	Deutsch	Italiano	Español
Large truss head	Tête large	Rundkopf extragroß	Testa larga	Cabeza ancha
Pin: Carbon steel Zinc plated 15µm Clear trivalent passivated	Tige: Acier Revêtement zingué 15µm Passivation claire trivalente	Bolzen: Stahl Verzinkt 15µm Klar chromatiert, Cr6-frei	Bullone: Acciaio Zincato 15µm Passivazione chiara trivalente	Vástago: Acero Zincado 15µm Pasivado claro trivalente
Collar: Low carbon steel Zinc plated, 10 µm	Bague: Acier bas carbone Zingué, 10 µm	Schließring: Stahl Verzinkt, 10 µm	Collare: Acciaio a basso tenore di carbonio Zincato, 10 µm	Collar: Acero bajo en carbono Zincado, 10 µm

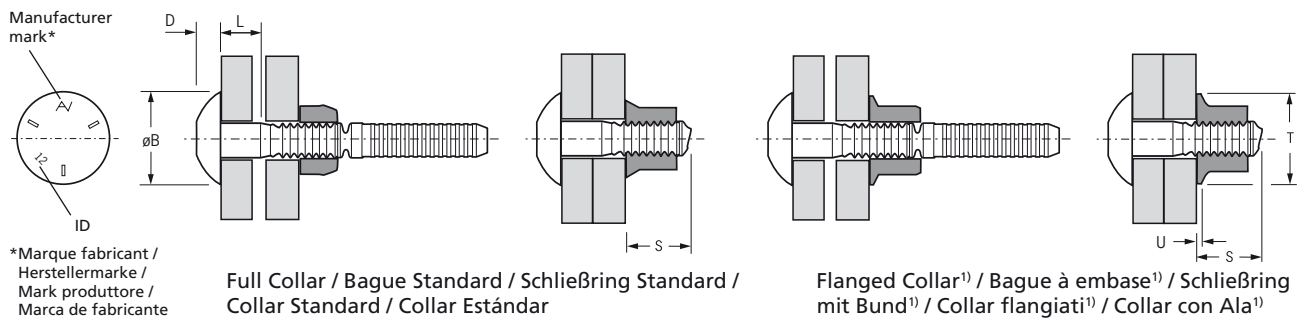

ø	ID			L	øB	D	Part No/ref					
	nom.	min.	max.				Pin	Full Collar S max.	Flanged Collar ¹⁾ S max.	øT max.	U ¹⁾	
12.7 (1/2")	4	6.35	12.70	4.60	13.5	29.0	7.8	02854-01604	02662-01600	26.5	02615-01600	29.7 26.2 3.18
	8	12.70	19.05	10.95				02854-01608				
	12	19.05	25.40	17.30				02854-01612				
	16	25.40	31.75	23.65				02854-01616				
	20	31.75	38.10	30.00				02854-01620				
	24	38.10	44.45	36.35				02854-01624				
	28	44.45	50.80	42.70				02854-01628				
	32	50.80	57.15	49.05				02854-01632				
	36	57.15	63.50	55.40				02854-01636				
	40	63.50	69.85	61.75				02854-01640				
	44	69.85	76.20	68.10				02854-01644				
	48	76.20	82.55	74.45				02854-01648				
	52	82.55	88.90	80.80				02854-01652				
	56	88.90	95.25	87.15				02854-01656				
	60	95.25	101.60	93.50				02854-01660				
	64	101.60	107.95	99.85				02854-01664				
	68	107.95	114.30	106.20				02854-01668				
	72	114.30	120.65	112.55				02854-01672				
76	120.65	127.00	118.90	02854-01676								
80	127.00	133.35	125.25	02854-01680								

all dimensions in mm / en millimètre / alle Maße in mm / in millimetri / en milímetros

1) Flanged collars are used in applications where the hole on the collar side of the application is oversize or is slotted for alignment purposes. To determine what length of pin is required, add dimension U to the thickness of material being fastened.

Avec une bague à embase, la plage de serrage est diminuée de la valeur de la cote U.

Schließringe mit Bund werden in Anwendungen benötigt, wo das Bohrloch auf der Schließringseite übergroß oder länglich ist. Um den richtigen Bolzen zu bestimmen, addieren Sie das Maß U zu der zu verbindenden Materialstärke hinzu.

Utilizzando i collari flangiati la dimensione „U“ deve essere aggiunta allo spessore da serrare per determinare il tipo di bullone adatto.

Utilizar collar con ala cuando en la aplicación el barreno está sobredimensionado o es ranurado para propósitos de alineación. Para calcular la referencia de perno es necesario añadir la cota U al espesor de la aplicación.

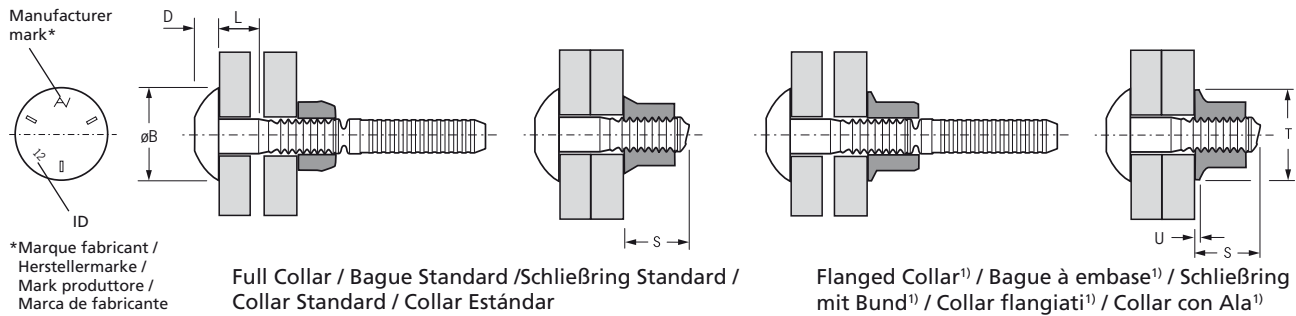

*Marque fabricant /
Herstellermarke /
Mark produttore /
Marca de fabricante

Full Collar / Bague Standard / Schließring Standard /
Collar Standard / Collar Estándar

Flanged Collar¹⁾ / Bague à embase¹⁾ / Schließring
mit Bund¹⁾ / Collar flangiati¹⁾ / Collar con Ala¹⁾

ø nom.	ID			L nom.	øB max.	D max.	Part No/ref						
	min.	max.	Pin				Full Collar S max.	Flanged Collar ¹⁾ S max. øT max. U ¹⁾					
15.9 (5/8")	4	6.35	12.70	4.60	16.7	36.5	9.2	02854-02004	02662-02000	02615-02000			
	8	12.70	19.05	10.95									02854-02008
	12	19.05	25.40	17.30									02854-02012
	16	25.40	31.75	23.65									02854-02016
	20	31.75	38.10	30.00									02854-02020
	24	38.10	44.45	36.35									02854-02024
	28	44.45	50.80	42.70									02854-02028
	32	50.80	57.15	49.05									02854-02032
	36	57.15	63.50	55.40									02854-02036
	40	63.50	69.85	61.75									02854-02040
	44	69.85	76.20	68.10									02854-02044
	48	76.20	82.55	74.45									02854-02048
	52	82.55	88.90	80.80									02854-02052
	56	88.90	95.25	87.15									02854-02056
	60	95.25	101.60	93.50									02854-02060
	64	101.60	107.95	99.85									02854-02064
	68	107.95	114.30	106.20									02854-02068
72	114.30	120.65	112.55	02854-02072									
76	120.65	127.00	118.90	02854-02076									
19.1 (3/4")	4	6.35	12.70	4.60	19.9	43.6	10.9	02854-02404	02662-02400	02615-02400			
	8	12.70	19.05	10.95									02854-02408
	12	19.05	25.40	17.30									02854-02412
	16	25.40	31.75	23.65									02854-02416
	20	31.75	38.10	30.00									02854-02420
	24	38.10	44.45	36.35									02854-02424
	28	44.45	50.80	42.70									02854-02428
	32	50.80	57.15	49.05									02854-02432
	36	57.15	63.50	55.40									02854-02436
	40	63.50	69.85	61.75									02854-02440
	44	69.85	76.20	68.10									02854-02444
	48	76.20	82.55	74.45									02854-02448
	52	82.55	88.90	80.80									02854-02452
	56	88.90	95.25	87.15									02854-02456
	60	95.25	101.60	93.50									02854-02460
	64	101.60	107.95	99.85									02854-02464
	68	107.95	114.30	106.20									02854-02468
72	114.30	120.65	112.55	02854-02472									
76	120.65	127.00	118.90	02854-02476									

all dimensions in mm / en millimètre / alle Maße in mm / in millimetri / en milímetros

1) Flanged collars are used in applications where the hole on the collar side of the application is oversize or is slotted for alignment purposes. To determine what length of pin is required, add dimension U to the thickness of material being fastened.

Avec une bague à embase, la plage de serrage est diminuée de la valeur de la cote U.

Schließringe mit Bund werden in Anwendungen benötigt, wo das Bohrloch auf der Schließringseite übergroß oder länglich ist. Um den richtigen Bolzen zu bestimmen, addieren Sie das Maß U zu der zu verbindenden Materialstärke hinzu.

Utilizzando i collari flangiati la dimensione „U“ deve essere aggiunta allo spessore da serrare per determinare il tipo di bullone adatto.

Utilizar collar con ala cuando en la aplicación el barreno está sobredimensionado o es ranurado para propósitos de alineación. Para calcular la referencia de perno es necesario añadir la cota U al espesor de la aplicación.

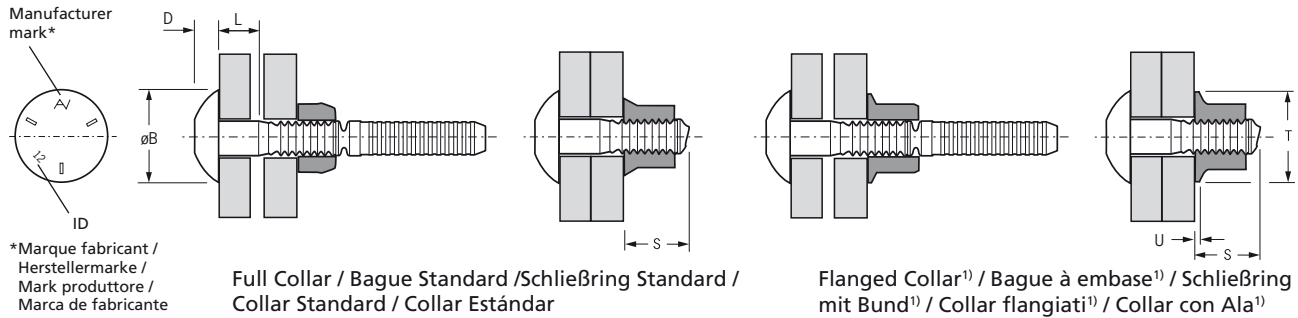

*Marque fabricant /
Herstellermarke /
Mark produttore /
Marca de fabricante

Full Collar / Bague Standard / Schließring Standard /
Collar Standard / Collar Estándar

Flanged Collar¹⁾ / Bague à embase¹⁾ / Schließring
mit Bund¹⁾ / Collar flangiati¹⁾ / Collar con Ala¹⁾

ø nom.	ID			L nom.	øB max.	D max.	Part No/ref						
	min.	max.	Pin				Full Collar S max.	Flanged Collar ¹⁾ S max. øT max. U ¹⁾					
22.2 (7/8")	8	12.70	19.05	10.95	23.1	50.8	12.8	02854-02808	02662-02800	02615-02800 44.7 41.3 5.54			
	12	19.05	25.40	17.30									02854-02812
	16	25.40	31.75	23.65									02854-02816
	20	31.75	38.10	30.00									02854-02820
	24	38.10	44.45	36.35									02854-02824
	28	44.45	50.80	42.70									02854-02828
	32	50.80	57.15	49.05									02854-02832
	36	57.15	63.50	55.40									02854-02836
	40	63.50	69.85	61.75									02854-02840
	44	69.85	76.20	68.10									02854-02844
	48	76.20	82.55	74.45									02854-02848
	52	82.55	88.90	80.80									02854-02852
	56	88.90	95.25	87.15									02854-02856
	60	95.25	101.60	93.50									02854-02860
	64	101.60	107.95	99.85									02854-02864
68	107.95	114.30	106.20	02854-02868									
72	114.30	120.65	112.55	02854-02872									
25.4 (1")	8	12.70	19.05	10.95	26.2	58.1	14.6	02854-03208	02662-03200	02615-03200 49.6 48.5 6.35			
	12	19.05	25.40	17.30									02854-03212
	16	25.40	31.75	23.65									02854-03216
	20	31.75	38.10	30.00									02854-03220
	24	38.10	44.45	36.35									02854-03224
	28	44.45	50.80	42.70									02854-03228
	32	50.80	57.15	49.05									02854-03232
	36	57.15	63.50	55.40									02854-03236
	40	63.50	69.85	61.75									02854-03240
	44	69.85	76.20	68.10									02854-03244
	48	76.20	82.55	74.45									02854-03248
	52	82.55	88.90	80.80									02854-03252
	56	88.90	95.25	87.15									02854-03256
	60	95.25	101.60	93.50									02854-03260
	64	101.60	107.95	99.85									02854-03264
	68	107.95	114.30	106.20									02854-03268
	72	114.30	120.65	112.55									02854-03272
	76	120.65	127.00	118.90									02854-03276
80	127.00	133.35	125.25	02854-03280									
84	133.35	139.70	131.60	02854-03284									
88	139.70	146.05	137.95	02854-03288									
92	146.05	152.40	144.30	02854-03292									

all dimensions in mm / en millimètre / alle Maße in mm / in millimetri / en milímetros



1) Flanged collars are used in applications where the hole on the collar side of the application is oversized or is slotted for alignment purposes. To determine what length of pin is required, add dimension U to the thickness of material being fastened.

Avec une bague à embase, la plage de serrage est diminuée de la valeur de la cote U.

Schließringe mit Bund werden in Anwendungen benötigt, wo das Bohrloch auf der Schließringseite übergroß oder länglich ist. Um den richtigen Bolzen zu bestimmen, addieren Sie das Maß U zu der zu verbindenden Materialstärke hinzu.

Utilizzando i collari flangiati la dimensione „U“ deve essere aggiunta allo spessore da serrare per determinare il tipo di bullone adatto.

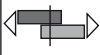
Utilizar collar con ala cuando en la aplicación el barreno está sobredimensionado o es ranurado para propósitos de alineación. Para calcular la referencia de perno es necesario añadir la cota U al espesor de la aplicación.

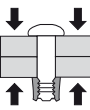
ø			
nom.	kN min.	kN min.	kN min.
12.7	64.0	75.8	53.6
15.9	100.0	120.5	85.4
19.1	144.4	178.3	126.3
22.2	193.0	246.6	174.6
25.4	251.3	323.3	229.1

Installed Avdelok XT fasteners provide a minimum shear, tensile and pre-load strength, which is equivalent to or exceeds ISO 898-1 property class 8.8 or ASTM A-325 standards. Made to British Standard B7805: Part 2:1997, the Avdelok XT fastener can be the perfect alternative to conventional property class 8.8 threaded fasteners, providing a permanent, high tensile friction grip joint but without the risk of loosening.

Une fois posées les fixations Avdelok XT proposent des performances de résistance au cisaillement et à l'arrachement et une prétension qui sont équivalentes ou meilleures que les propriétés d'une ISO 898-1 classe 8.8 ou de la norme ASTM A-325. Fabriquée selon la norme Anglaise B7805: Part 2:1997, la fixation Avdelok XT peut être une parfaite alternative aux boulons traditionnels de classe 8.8 et offre un assemblage permanent, haute résistance sans risque de desserrage.

Verarbeitete Avdelok XT Schließringbolzen bieten Mindestwerte für Scher- und Zugbruchlast sowie Vorspannkraft, die der ISO 898-1 Festigkeitsklasse 8.8 oder ASTM A-325 Standards entsprechen oder übertreffen. Avdelok XT werden nach British Standard B7805: Part 2:1997 hergestellt. Sie können die perfekte Alternative zu herkömmlichen 8.8 Gewindeprodukten sein und bieten eine dauerhafte, hochfest vorgespannte Verbindung ohne Risiko des ungewollten Lösen.

I bulloni a strappo Avdelok XT, una volta installati sono paragonabili o superiori alle ISO 898-1 classi di resistenza 8.8 o ASTM A-325. Costruiti secondo le norme Britanniche B7805: Parte 2:1997, i bulloni a strappo Avdelok XT possono essere perfettamente alternativi al grado di resistenza 8.8 dei bulloni tradizionali, garantendo però un sicuro e permanente serraggio senza rischi di manomissione.



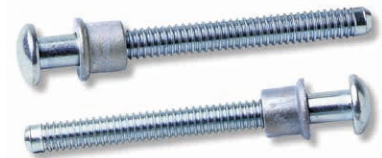

Los remaches Avdelok XT proporcionan una resistencia a cortadura y a tracción y proporcionan una fuerza de apriete, equivalentes o superiores a la tornillería de ISO 898-1 clase 8.8 o ASTM A-325. Fabricados bajo la norma British Standard B7805, parte 2:1997, los remaches Avdelok XT pueden ser una alternativa perfecta a la tornillería tradicional de clase 8.8, proporcionando una alta fricción permanente entre las piezas a unir sin el riesgo de aflojado que tienen las uniones atornilladas.

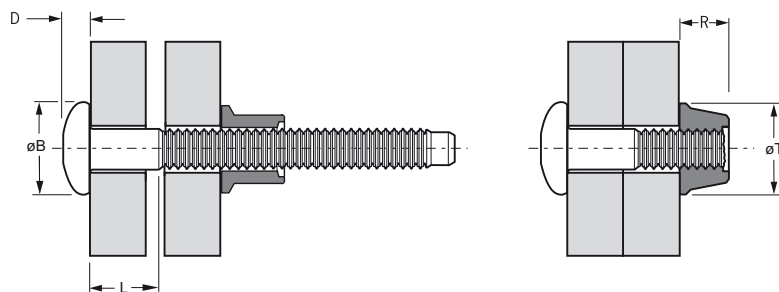

English	Français	Deutsch	Italiano	Español
Brazier head	Tête plate	Flachrundkopf	Testa tonda	Cabeza alomada
Pin: Medium carbon steel*	Tige: Acier*	Bolzen: Stahl*	Bullone: Acciaio a carbonio*	Vástago: Acero medio al carbono*
Zinc plated	Revêtement zingué	Verzinkt	Zincato	Zincado
Clear trivalent passivated	Passivation claire trivalente	Klar chromatiert, Cr6-frei	Passivazione chiara trivalente	Pasivado claro trivalente
Collar: Low carbon steel**	Bague: Acier bas carbone**	Schließring: Stahl**	Collare: Acciaio a basso tenore di carbonio**	Collar: Acero bajo en carbono**
Zinc plated	Revêtement zingué	Verzinkt	Zincato	Zincado
Clear trivalent passivated	Passivation claire trivalente	Klar chromatiert, Cr6-frei	Passivazione chiara trivalente	Pasivado claro trivalente

*: BS 3111 Type 10, SAE 10B35 DIN 1654, 35B2 **: SAE 1008 EN 10263-2 C8C



ø				øB	D	L	R	øT			Part No/ref	Part No/ref
	nom.	min.										
4.8 (3/16")	1.6	15.9	5.16	10.1	3.2	2.3	8.7	10.1	8.25	10.01	01901-70610	01981-70600
	7.9	31.7				8.4					01901-70620	
6.4 (1/4")	1.6	15.9	6.75	13.3	3.9	2.2	13.5	13.2	11.79	16.01	01901-70810	01981-70800
	7.9	31.7				9.1					01901-70820	

all dimensions in mm / en millimètre / alle Maße in mm / in millimetri / en milímetros

1) typical values / valeurs moyennes / typische Werte / Valori tipici / valores típicos



English	Français	Deutsch	Italiano	Español
90° Countersunk	90° Tête fraisée	90° Senkkopf	90° Testa svasata	90° Cabeza avellanada
Pin: Medium carbon steel*	Tige: Acier*	Bolzen: Stahl*	Bullone: Acciaio a carbonio*	Vástago: Acero medio al carbono*
Zinc plated	Revêtement zingué	Verzinkt	Zincato	Zincado
Clear trivalent passivated	Passivation claire trivalente	Klar chromatiert, Cr6-frei	Passivazione chiara trivalente	Pasivado claro trivalente
Collar: Low carbon steel**	Bague: Acier bas carbone**	Schließring: Stahl**	Collare: Acciaio a basso tenore di carbonio**	Collar: Acero bajo en carbono**
Zinc plated	Revêtement zingué	Verzinkt	Zincato	Zincado
Clear trivalent passivated	Passivation claire trivalente	Klar chromatiert, Cr6-frei	Passivazione chiara trivalente	Pasivado claro trivalente

*: BS 3111 Type 10, SAE 10B35, DIN 1654, 35B2 **: SAE 1008 EN 10263-2 C8C

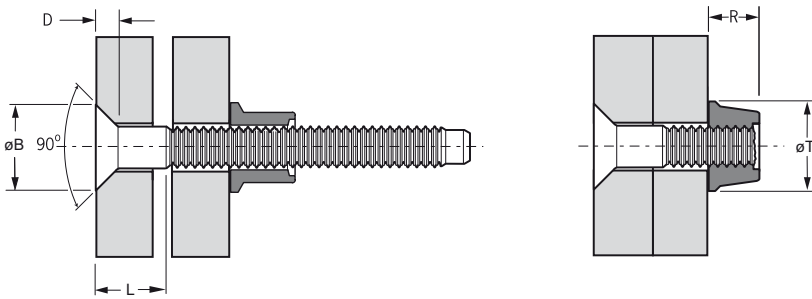

ø	Ø		ØB	D	L	R	øT	kN ¹⁾	kN ¹⁾	Part No/ref	Part No/ref	
	min.	max.										max.
4.8 (3/16")	2.4	15.9	5.16	8.9	2.2	4.3	8.7	10.1	8.25	10.01	01902-70610	01981-70600
	7.9	31.7				9.4					01902-70620	

all dimensions in mm / en millimètre / alle Maße in mm / in millimetri / en milímetros



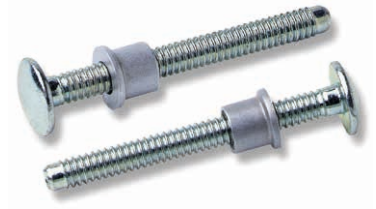

1) typical values / valeurs moyennes / typische Werte / Valori tipici / valores típicos

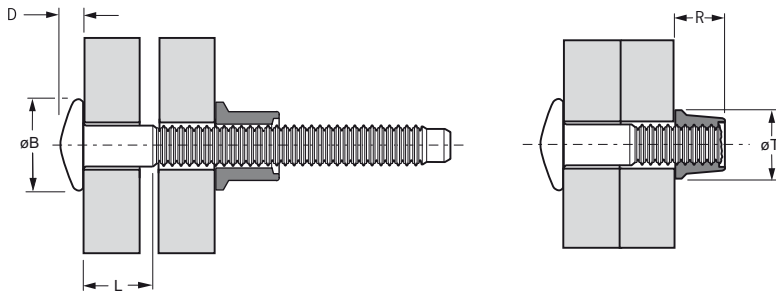

English	Français	Deutsch	Italiano	Español
Mushroom head	Tête large	Rundkopf groß	Testa larga	Cabeza alomada de perfil alto
Pin: Medium carbon steel* Zinc plated Clear trivalent passivated	Tige: Acier* Revêtement zingué Passivation claire trivalente	Bolzen: Stahl* Verzinkt Klar chromatiert, Cr6-frei	Bullone: Acciaio a carbonio* Zincato Passivazione chiara trivalente	Vástago: Acero medio al carbono* Zincado Pasivado claro trivalente
Collar: Low carbon steel** Zinc plated Clear trivalent passivated	Bague: Acier bas carbone** Revêtement zingué Passivation claire trivalente	Schließring: Stahl** Verzinkt Klar chromatiert, Cr6-frei	Collare: Acciaio a basso tenore di carbonio** Zincato Passivazione chiara trivalente	Collar: Acero bajo en carbono** Zincado Pasivado claro trivalente

*: BS 3111 Type 10, SAE 10B35, DIN 1654, 35B2 **: SAE 1008 EN 10263-2 C8C



ø				øB	D	L	R	øT			Part No/ref	Part No/ref
	nom.	min.										
4.8 (3/16")	1.6	15.9	5.16	12.5	2.9	2.3	8.7	10.1	8.25	10.01	01903-70610	01981-70600
	7.9	31.7				8.4					01903-70620	
6.4 (1/4")	1.6	15.9	6.75	16.7	3.2	2.2	13.5	13.2	11.79	16.01	01903-70810	01981-70800
	7.9	31.7				9.1					01903-70820	
	27.9	51.7				29.1					01903-70832	

all dimensions in mm / en millimètre / alle Maße in mm / in millimetri / en milímetros

1) typical values / valeurs moyennes / typische Werte / Valori tipici / valores típicos



English	Français	Deutsch	Italiano	Español
Truss head	Tête large	Flachrundkopf groß	Testa larga	Cabeza alomada de perfil bajo
Pin: Medium carbon steel* Zinc plated Clear trivalent passivated	Tige: Acier* Revêtement zingué Passivation claire trivalente	Bolzen: Stahl* Verzinkt Klar chromatiert, Cr6-frei	Bullone: Acciaio a carbonio* Zincato Passivazione chiara trivalente	Vástago: Acero medio al carbono* Zincado Pasivado claro trivalente
Collar: Low carbon steel** Zinc plated Clear trivalent passivated	Bague: Acier bas carbone** Revêtement zingué Passivation claire trivalente	Schließring: Stahl** Verzinkt Klar chromatiert, Cr6-frei	Collare: Acciaio a basso tenore di carbonio** Zincato Passivazione chiara trivalente	Collar: Acero bajo en carbono** Zincado Pasivado claro trivalente

*: BS 3111 Type 10, SAE 10B35, DIN 1654, 35B2 **: SAE 1008 EN 10263-2 C8C

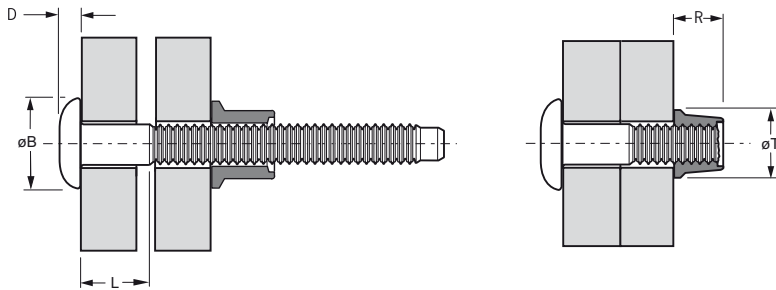

ø	Ø		ØB	D	L	R	øT	kN ¹⁾	kN ¹⁾	Part No/ref	Part No/ref	
	min.	max.										max.
4.8 (3/16")	1.6	15.9	5.16	12.0	2.9	2.3	8.7	10.1	8.25	10.01	01905-70610	01981-70600
	7.9	31.7									01905-70620	
6.4 (1/4")	1.6	15.9	6.75	15.2	3.1	2.2	13.5	13.2	11.79	16.01	01905-70810	01981-70800
	7.9	31.7									01905-70820	

all dimensions in mm / en millimètre / alle Maße in mm / in millimetri / en milímetros





1) typical values / valeurs moyennes / typische Werte / Valori tipici / valores típicos

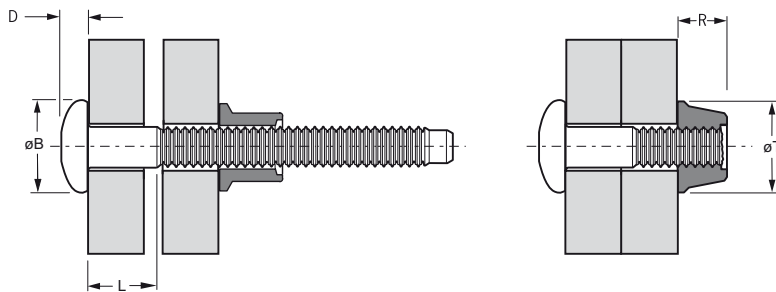

English	Français	Deutsch	Italiano	Español
Brazier head	Tête plate	Flachrundkopf	Testa tonda	Cabeza alomada
Pin: Aluminium alloy*	Tige: Alliage d'aluminium*	Bolzen: Aluminium*	Bullone: Lega di alluminio*	Vástago: Aluminio*
Polished	Poli	Poliert	Lucido	Pulido
Collar: Aluminium alloy*	Bague: Alliage d'aluminium*	Schließring: Aluminium*	Collare: Lega di alluminio*	Collar: Aluminio*
Natural	Brut	Blank	Nessuna finitura	Natural

*: EN AW-7075, AlZn5.5MgCu **: EN AW-6061, AlMg1SiCu



ø				øB	D	L	R	øT			Part No/ref	Part No/ref
	nom.	min.									max.	max.
4.8 (3/16")	1.6	15.9	5.16	10.0	3.4	2.3	7.9	9.9	4.23	5.78	01921-00610	01985-00600
	7.9	31.7				8.4					01921-00620	
6.4 (1/4")	1.6	15.9	6.75	13.3	4.2	2.2	11.1	13.0	7.45	9.79	01921-00810	01985-00800
	7.9	31.7				9.1					01921-00820	

all dimensions in mm / en millimètre / alle Maße in mm / in millimetri / en milímetros



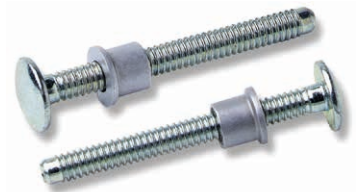

1) typical values / valeurs moyennes / typische Werte / Valori tipici / valores típicos

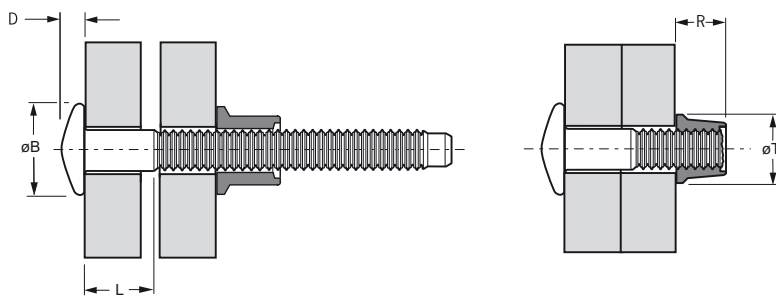

English	Français	Deutsch	Italiano	Español
Mushroom head	Tête large	Rundkopf groß	Testa larga	Cabeza alomada de perfil alto
Pin: Aluminium alloy*	Tige: Alliage d'aluminium*	Bolzen: Aluminium*	Bullone: Lega di alluminio*	Vástago: Aluminio*
Polished	Poli	Poliert	Lucido	Pulido
Collar: Aluminium alloy**	Bague: Alliage d'aluminium**	Schließring: Aluminium**	Collare: Lega di alluminio**	Collar: Aluminio**
Natural	Brut	Blank	Nessuna finitura	Natural

*: BS 1473 7075, DIN 1725, AlZnMgCu1.5, Werkstoff 3.4365 **: BS 1473 6061, DIN 1725, AlMg1SiCu, Werkstoff 3.3211



ø				øB	D	L	R	øT			Part No/ref	Part No/ref
	nom.	min.									max.	max.
4.8 (3/16")	1.6	15.9	5.16	12.5	2.8	2.3	7.9	9.9	4.23	5.78	01923-00610	01985-00600
	7.9	31.7				8.4					01923-00620	

all dimensions in mm / en millimètre / alle Maße in mm / in millimetri / en milímetros





1) typical values / valeurs moyennes / typische Werte / Valori tipici / valores típicos

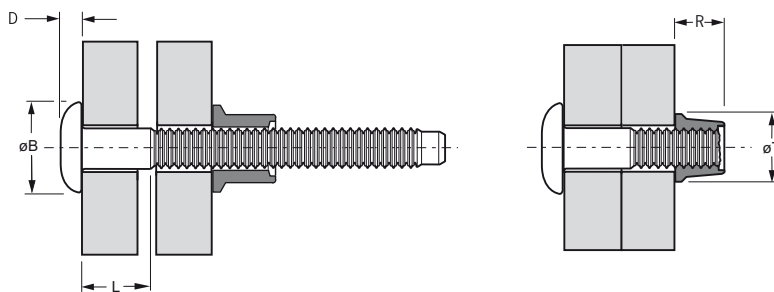

English	Français	Deutsch	Italiano	Español
Truss head	Tête large	Flachrundkopf groß	Testa larga	Cabeza alomada de perfil bajo
Pin: Aluminium alloy*	Tige: Alliage d'aluminium*	Bolzen: Aluminium*	Bullone: Lega di alluminio*	Vástago: Aluminio*
Polished	Poli	Poliert	Lucido	Pulido
Collar: Aluminium alloy**	Bague: Alliage d'aluminium**	Schließring: Aluminium**	Collare: Lega di alluminio**	Collar: Aluminio**
Natural	Brut	Blank	Nessuna finitura	Natural

*: 7075 **: 6061



ø				øB	D	L	R	øT			Part No/ref	Part No/ref
	nom.	min.										
4.8 (3/16")	1.6	15.9	5.16	12.0	2.8	2.3	7.9	9.9	4.23	5.78	01925-00610	01985-00600
	7.9	31.7				8.4					01925-00620	
6.4 (1/4")	1.6	15.9	6.75	15.1	3.1	2.2	11.1	13.1	7.45	9.79	01925-00810	01985-00800
	7.9	31.7				9.1					01925-00820	

all dimensions in mm / en millimètre / alle Maße in mm / in millimetri / en milímetros

1) typical values / valeurs moyennes / typische Werte / Valori tipici / valores típicos



English	Français	Deutsch	Italiano	Español
Low profile head	Profil bas	Flachkopf	Basso profilo	Perfil bajo
Pin: Low carbon steel*	Tige: Acier*	Bolzen: Stahl*	Bullone: Acciaio a carbonio*	Vástago: Acero al carbono*
Zinc plated JS500 coated	Revêtement zingué Finition JS 500	Verzinkt JS500 Beschichtung	Zincato Protezione JS500	Zincado Pasivado JS500
Shell: Low carbon steel**	Bague: Acier bas carbone**	Hülse: Stahl**	Collare: Acciaio a basso tenore di carbonio**	Collar: Acero bajo en carbono**
Zinc plated Clear passivated	Revêtement zingué Passivation claire	Verzinkt Klar chromatiert, Cr6-frei	Zincato Passivazione chiara	Zincado Pasivado claro
Locking slug: Nylon	Manchon: Nylon	Sicherungsbuchse: Nylon	Tubolare: Nylon	Junta de bloqueo: Nailon
Seal: Santoprene®	Joint: Santoprene®	Dichtscheibe: Santoprene®	Guarnizione: Santoprene®	Junta de estanqueidad: Santoprene®

*: BS 3111 Type 0 DIN 1654 Qst 34-3 **: BS 1449 CS 1 SAE 1008 DIN 1614 StW 24 / DIN 1624 St4

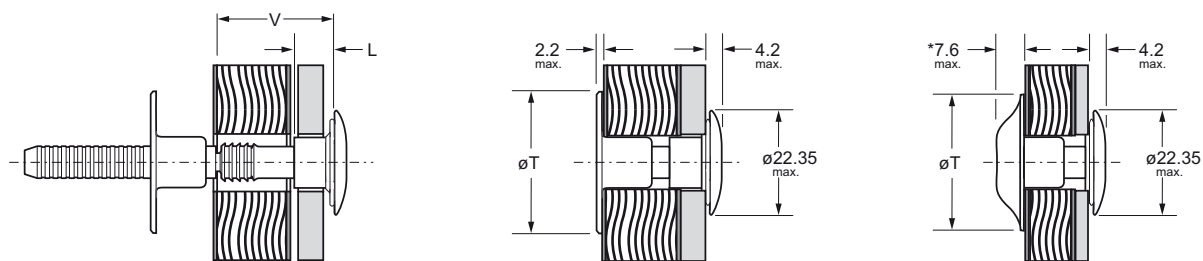

*02310-11860 only /
seulement/nur/solo/solo



ø nom.	e		V nom.	L nom.	kN ¹⁾	kN ¹⁾		Part No/ref Pin	Collar / Bague / Hülse / Collare / Collar			
	min.	max.				e min.	e max.		øT	Part No/ref.		
10.0 (3/8")	5.60	7.20	11.1	-	2.22	6.60	4.44	02311-01207 ²⁾	30.5	02310-11860		
	11.13	14.30	12.7	-				02311-01208 ²⁾	32.0	02321-01200 ³⁾		
	12.70	15.87	14.3	-				02311-01209 ²⁾				
	14.27	17.45	15.9	-				02311-01210 ²⁾				
	15.87	19.05	17.5	4.6				02311-01211				
	17.45	20.62	19.0	6.1				02311-01212				
	19.05	22.22	20.6	7.9				02311-01213				
	20.62	23.80	22.2	9.4				02311-01214				
	22.22	25.40	23.8	10.9				02311-01215				
	23.80	26.97	25.4	12.5				02311-01216			22.9	02325-01200 ⁴⁾
	25.40	28.57	27.0	14.2				02311-01217				
	26.97	30.15	28.6	14.2				02311-01218				
	28.57	31.75	30.2	14.2				02311-01219				
	30.15	33.32	31.7	14.2				02311-01220				
	31.75	34.92	33.3	14.2				02311-01221				
	33.32	36.50	34.9	14.2				02311-01222				
	34.93	38.10	36.5	14.2				02311-01223				
	36.50	39.67	38.1	14.2				02311-01224				

all dimensions in mm / en millimètre / alle Maße in mm / in millimetri / en milímetros

1) - 5) see next page / voir la page suivant / siehe nächste Seite / vedi pagina successiva / ver la página siguiente

- 1) typical values / valeurs moyennes / typische Werte / Valori tipici / valores típicos
- 2) Part numbers -01207, -01208, -01209 & -01210 do not have shouldered pins. / Les références -01207, -01208, -01209 & -01210 ne possèdent pas d'épaulement. / Artikel-Nr. -01207, -01208, -01209 & -01210 haben keine Stufe im Bolzenschaft / Codici prodotto -01207, -01208, -01209 & -01210 non hanno lo spallamento. / Las referencias -01207, -01208, -01209 & -01210 no tienen el cuerpo escalonado.
- 3) 02321-01200: The larger shell assembly is for use against softer material, spreading the bearing load. / La bague standard 02321-01200 est à utiliser sur des matériaux tendre, pour une meilleure répartition des efforts. / Die größere Hülse ist für den Einsatz gegen weichere Materialien ausgelegt, die auftretende Kraft wird verteilt. / Collare di grande diametro per materiali teneri. / Collar de diámetro major para materiales blandos.
- 4) 02325-01200: The smaller shell assembly should only be used against metal surfaces. / La bague à diamètre réduit ne peut être utilisée qu'en appui sur un support métallique. / Die kleinere Hülse darf nur auf Metalloberflächen eingesetzt werden. / Collare di piccolo diametro per superfici metalliche. / Collar de diámetro menor para superficies metálicas.
- 5) Where shells are used against metal surfaces, the hole through the metal should be 15 mm diameter or chamfered 2.5 mm x 45° / Lorsque la bague prend appui sur un support métallique, percer à 15 mm de \varnothing ou chanfreiner l'entrée du trou à 45° x 2.5 / Bei Auflage der Hülse auf Metall ist im Metall eine 2,5 x 45°-Senkung oder ein Bohrungsdurchmesser von 15 mm erforderlich. / Quando i guschi sono usati su parti metalliche, il foro nella lamiera dovrebbe avere un diametro di 15mm o deve presentare una svasatura di 2,5mm a 45°. / Cuando el collar se utiliza sobre superficies metálicas, el barreno en la pieza metálica debe de ser de 15 mm o tener un avellanado de entrada de 2,5x45°.





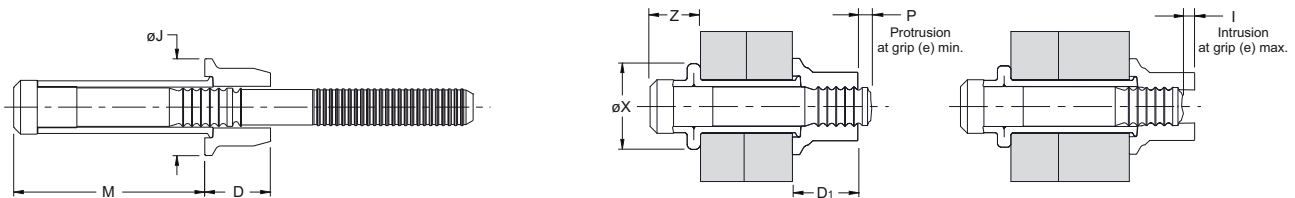

English	Français	Deutsch	Italiano	Español	****
Stem: Chromium Molybdenum steel* Black oxide	Tige: Acier* Noir	Dorn: Stahl* Schwarz	Gambo: Acciaio* Passivato nero	Vástago: Acero* Pavonado	 8 h
Sleeve: Carbon steel** Zinc plated Clear trivalent passivated	Douille: Acier** Revêtement zingué Passivation claire trivalente	Hülse: Stahl** Verzinkt Klar chromatiert, Cr6-frei	Bussola: Acciaio** Zincata Passivazione chiara trivalente	Cuerpo: Acero** Zincado Pasivado claro trivalente	 240 h
Collar: Carbon steel*** Zinc plated Clear trivalent passivated	Bague: Acier*** Revêtement zingué Passivation claire trivalente	Schließring: Stahl*** Verzinkt Klar chromatiert, Cr6-frei	Collare: Acciaio*** Zincato Passivazione chiara trivalente	Collar: Acero*** Zincado Pasivado claro trivalente	 240 h

*: EN 10263-4 34CrMo4 SAE 4135 SCM435 ** : EN 10263-2 C8C SAE 1008 ***: EN 10263-4 23MnB4
****: to red rust / à la rouille rouge / bis Rotrost / alla ruggine rossa / al óxido rojo (ASTM B117)

Avbolt fasteners are supplied with lubricated collars and must not be degreased. / Avbolt sont lubrifiées et ne doivent pas être dégraissées. / Avbolt sind mit einem Gleitmittel beschichtet, welches nicht entfernt werden darf. / I Avbolt sono forniti lubrificati e non devono essere sgrassati. / Los Avbolt se suministran con collares lubricados y no deben ser desengrasados.



ø nom.					M max.	øJ max.	D max.	øX nom.	Z max.	D ₁ nom.	P max.	I max.	 kN min. ¹⁾	 kN min. ¹⁾	Part No/ref
	min.	max.	min.	max.											
10.0 (3/8")	4.78	7.95	10.49	11.05	25.10	18.77	12.65	15.49	9.58	14.50	4.36	1.72	45.00	32.25	21001-01204
	7.95	11.13			28.27										21001-01206
	9.54	12.72			30.02										21001-01207
	11.13	14.30			31.45										21001-01208
	14.30	17.48			34.62										21001-01210
	17.48	20.65			37.80										21001-01212
	20.65	23.83			40.97										21001-01214
	23.83	27.00			44.15										21001-01216
	27.00	30.18			47.32										21001-01218
	30.18	33.35			50.50										21001-01220
12.7 (1/2")	6.38	9.55	13.87	14.76	31.82	24.31	15.01	20.62	13.11	16.10	4.36	1.57	90.00	57.00	21001-01604
	9.55	12.73			35.00										21001-01606
	12.73	15.90			38.18										21001-01608
	15.90	19.08			41.36										21001-01610
	19.08	22.25			44.53										21001-01612
	22.25	25.43			47.70										21001-01614
	25.43	28.60			50.87										21001-01616
	28.60	31.78			54.02										21001-01618
	31.78	34.95			57.16										21001-01620
	34.95	38.13			60.27										21001-01622
38.13	41.30	63.35	21001-01624												
16.0 (5/8")	6.35	12.70	17.45	18.49	39.35	29.46	17.45	25.4	16.01	20.07	7.93	1.98	129.00	91.19	21001-02004
	12.70	19.05			45.70										21001-02008
	19.05	25.40			52.05										21001-02012
	25.40	31.75			58.40										21001-02016
	31.75	38.10			64.75										21001-02020

all dimensions in mm / en millimètres / alle Maße in mm / in millimetri / en milímetros

1) Strength values apply only where the joint thickness exceeds 150% of the joint hole diameter.
Les valeurs de résistances mécaniques sont applicables uniquement lorsque l'épaisseur à serrer dépasse 150% du diamètre du trou de l'application.
Die Festigkeitswerte gelten nur bei einem Klemmbereich größer als 150% des Lochdurchmessers.
I valori di resistenza si applicano solamente laddove lo spessore da serrare supera il 150% del diametro del foro.
Los valores de resistencia sólo se aplican si el espesor total de la aplicación supera el 150% del diámetro del remache.







English	Français	Deutsch	Italiano	Español	***
Body: Carbon steel* Zinc plated Clear trivalent passivated	Corps: Acier* Revêtement zingué Passivation claire trivalente	Hülse: Stahl* Verzinkt Klar chromatiert, Cr6-frei	Corpo: Acciaio* Zincata Passivazione chiara trivalente	Cuerpo: Acero al carbono* Zincado, Pasivado claro trivalente	 240 h
Stem: Carbon steel** Black oxide	Tige: Acier** Noir	Dorn: Stahl** Schwarz brüniert	Gambo: Acciaio** Passivato nero	Vástago: Acero al carbono** Pavonado	 8 h

*: SAE 1008 EN 10263-2 C8C **: SCM 435 SAE 4135 EN 10263-4 34CrMo4

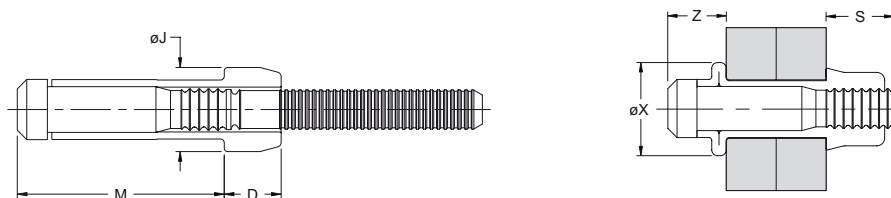
***: to red rust / à la rouille rouge / bis Rotrost / alla ruggine rossa / al óxido rojo (ASTM B117)

Bodies are supplied lubricated and must not be degreased. / Les corps sont lubrifiés et ne doivent pas être dégraissés. / Hülsen sind mit einem Gleitmittel beschichtet, welches nicht entfernt werden darf. / I corpi sono forniti lubrificati e non devono essere sgrassati. / Los cuerpos se suministran lubricados y no deben ser desengrasados.



ø nom.					M max.	øJ max.	D max.	S max.	øX nom.	Z max.	 kN min. ¹⁾	 kN min. ¹⁾	Part No/ref
	min.	max.	min.	max.									
4.8 (3/16")	2.36	3.99	5.28	5.64	12.41	7.32	4.95	6.38	7.54	5.35	12.40	8.00	21021-00602
	3.99	5.59			14.01								21021-00603
	5.59	7.16			15.59								21021-00604
	7.16	8.76			17.19								21021-00605
	8.76	10.34			18.76								21021-00606
	10.34	11.94			20.36								21021-00607
	11.94	13.51			21.94								21021-00608
	13.51	15.11			23.54								21021-00609
	15.11	16.69			25.11								21021-00610
	16.69	18.29			26.71								21021-00611
18.29	19.89	28.29	21021-00612										
6.4 (1/4")	2.36	3.99	7.04	7.42	16.51	9.70	6.61	8.76	9.84	7.24	22.69	14.46	21021-00802
	3.99	5.59			18.11								21021-00803
	5.59	7.16			19.69								21021-00804
	7.16	8.76			21.29								21021-00805
	8.76	10.34			22.86								21021-00806
	10.34	11.94			24.46								21021-00807
	11.94	13.51			26.04								21021-00808
	13.51	15.11			27.64								21021-00809
	15.11	16.69			29.21								21021-00810
	16.69	18.29			30.81								21021-00811
18.29	19.89	32.39	21021-00812										
8.0 (5/16")	4.78	7.95	8.84	9.35	23.31	12.39	8.61	10.25	12.28	9.10	36.47	23.57	21021-01004
	7.95	11.13			26.49								21021-01006
	11.13	14.30			29.66								21021-01008
	14.30	17.48			32.84								21021-01010
	17.48	20.65			36.01								21021-01012
	20.65	23.83			39.19								21021-01014
23.83	26.97	42.36	21021-01016										

all dimensions in mm / en millimètres / alle Maße in mm / in millimetri / en milímetros

1) Strength values apply only where the joint thickness exceeds 150% of the joint hole diameter.

Les valeurs de résistances mécaniques sont applicables uniquement lorsque l'épaisseur à sertir dépasse 150% du diamètre du trou de l'application.

Die Festigkeitswerte gelten nur bei einem Klemmbereich größer als 150% des Lochdurchmessers.

I valori di resistenza si applicano solamente laddove lo spessore da serrare supera il 150% del diametro del foro.

Los valores de resistencia sólo se aplican si el espesor total de la aplicación supera el 150% del diámetro del remache.

Notes

POP® & Avdel® have been producing assembly systems since the 1930s and offer comprehensive ranges of innovative fasteners and installation systems to all market segments and applications. STANLEY Engineered Fastening offers POP Avdel products through Sales, Distribution and Manufacturing facilities in over 150 countries. Covered by the portfolio are:



Breakstem Riveting Systems
Various features from multi-grip capability to high strength stainless steel rivets.



Lockbolt Systems
High clamp force and vibration resistance for the highest strength joints.



Speed Fastening® Systems
Extra fast and reliable fastening from one side. Rivets are fed automatically.



Sealing Plugs
Engineered for both low-pressure and high-pressure hole sealing applications.



Blind Rivet Nuts
Fast system for sustainable threads with high torque-to-turn.



Customised Fastener Designs
Bespoke designs and finishes to meet your unique assembly requirements.



Installation Equipment
From manually operated power tools to customised semi and fully automated assembly workstations and repair tools.

We can also provide you with:



One-stop shopping for the blind riveting distributor market. MasterFix® owes its excellent reputation to the successful distribution of the broadest range of blind rivets and blind rivet nuts in the business.



CribMaster® is the global leader in inventory & asset management solutions for industrial environments.



Spiralock® is a technologically superior fastening system ideally suited for threaded joint applications subjected to heavy shock and vibration.



CribMaster's comprehensive portfolio of vending machines & tool control solutions driven by a powerful software platform helps customers save 25% - 40% of costs associated with indirect material management, essential in the unrelenting drive towards efficiency & lower costs at manufacturing facilities today.

STANLEY®

Engineered Fastening

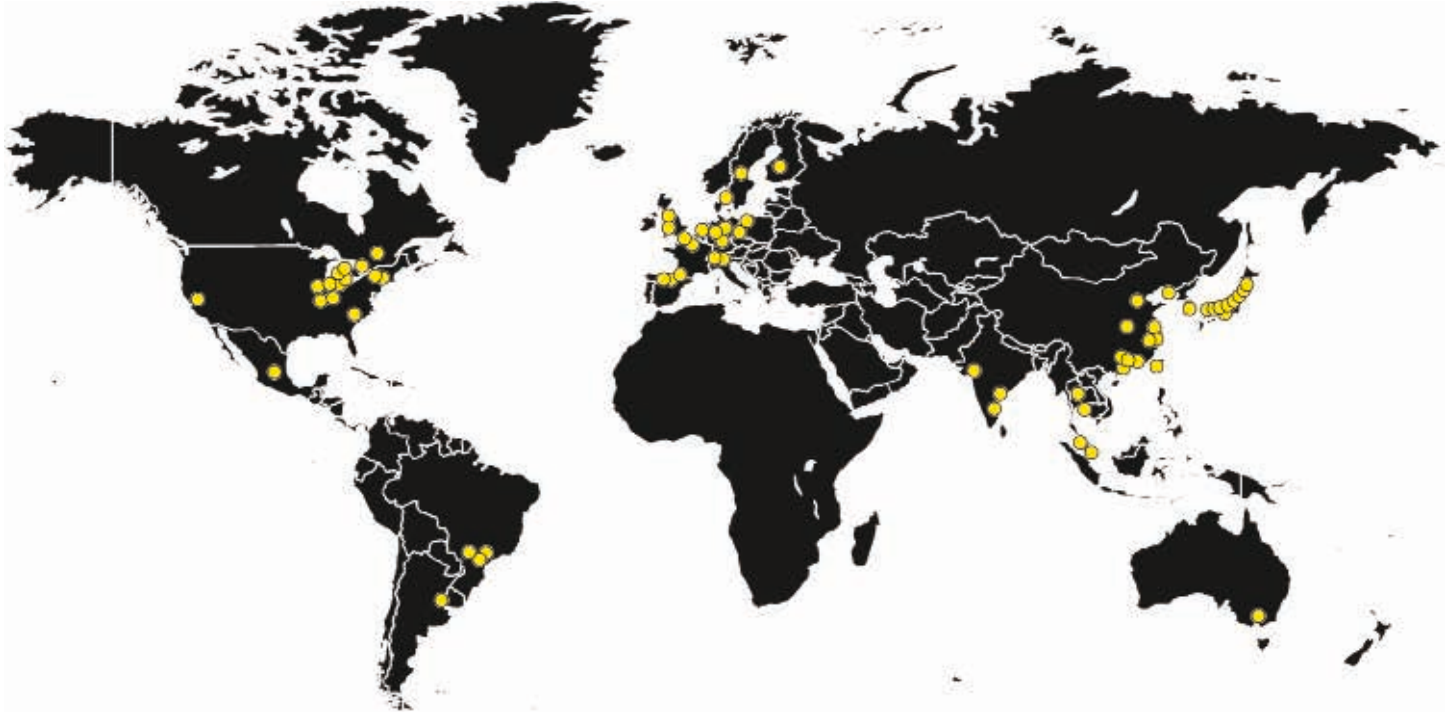

STANLEY Engineered Fastening, a Stanley Black & Decker Inc. Company has been revolutionizing fastening and assembly technologies for a variety of industries for more than 40 years.

For more information, please visit our website
www.StanleyEngineeredFastening.com

Quick Links:

- ▶ Our locations
<http://www.stanleyengineeredfastening.com/contact/global-locations>
- ▶ Request Information
<http://www.stanleyengineeredfastening.com/econtact/request-information>
- ▶ Resource Center
<http://www.stanleyengineeredfastening.com/resource-center>



© 2014 Stanley Black & Decker, Inc., Rev. 06.2017

AV™, Avbolt®, Avdel®, Avdelok®, Avtainer®, Genesis®, Maxlok®, NeoBolt®, POP®, ProSet®, and the "AV" symbol are trademarks of Stanley Black & Decker, Inc. and its affiliates. Santoprene® is a trademark of Advanced Elastomer Systems NV/SA. Enerpac® is a trademark of Actuant Corporation. DeltaSeal® is a trademark of Ewald Dörken AG.

Data shown is subject to change without prior notice as a result of continuous product development and improvement policy. Your local STANLEY Engineered Fastening representative is at your disposal should you need to confirm latest information.